

Reinco

HG-13GX3 HYDROGRASSER
SAFETY, OPERATION, PARTS & SERVICE
MANUAL

NOTICE

Every attempt has been made to make this manual complete, accurate and up-to-date. However, all information contained herein is subject to change due to updates and design modifications. Updated versions of this manual are available at www.reinco.com. All inquiries concerning this manual should be directed to **REINCO INC.**



CAUTION: The following information is **IMPORTANT** to the **HEALTH** and **SAFETY** of your employees. Please **READ**, take **ACTION** and **FILE** this document for future reference. Ask for additional copies if required.

STUDY THIS MANUAL CAREFULLY BEFORE ATTEMPTING TO OPERATE THE MACHINERY.



This safety alert symbol is used to call your attention to instructions concerning your personal safety.

Federal law requires you to explain the safety and operating instructions furnished with this machine to all employees before they are allowed to operate the machine. These instructions must be repeated to the employees at the beginning of each season. Be sure to observe and follow these instructions for you and your employee's safety.

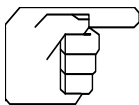

This symbol is used to draw attention to those operational and maintenance instructions we consider important to insure long trouble-free operation of this machine.

CALIFORNIA PROPOSITION 65 WARNING

**DIESEL ENGINE EXHAUST AND SOME OF ITS
CONSTITUENTS ARE KNOWN TO THE STATE OF
CALIFORNIA TO CAUSE CANCER, BIRTH DEFECTS AND
OTHER REPRODUCTIVE HARM.**

FORWARD

A MESSAGE FROM REINCO

Getting the most out of your new HG-13GX HYDROGRASSER should be within the reach of an inexperienced operator in a few hours. The purpose of this manual is to minimize start up difficulties and acquaint the new owner with recommended operating procedures and techniques. The following pages also include information on parts, service and accessories to help in making your new machine a versatile and profitable investment.

Your new REINCO HYDROGRASSER represents the culmination of over thirty-five years of expertise embodying field feedback, innovative design and manufacturing experience. Functional simplification and avoidance of mechanical complexities have been prime engineering objectives throughout this time. The benefits to be realized will be years of trouble free performance with minimum attention and maintenance.

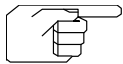

Every operator and supervisor must read this booklet and familiarize them self with the operational and mechanical aspects described. Some of the following commentary may appear to be obvious, but at the expense of being repetitive or assuming certain basics, this will serve as a guide for both owners and operators not acquainted with mulching procedures as well as providing instructions on the detailed operation of your new unit.

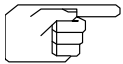

This manual is provided to ship with new units manufactured at the date of this document's revision. It is also supplied as a reference guide for units of similar construction, manufactured under prior designs. Some parts, options, engines, etc., may not be, or may not have been, available at the time of production of your machine. Contact **Reinco** for cost and availability of any requested upgrades.

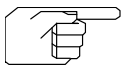

For references made to engines, consult the appropriate engine manufacturer's literature for applicable detailed information.

Reinco welcome this opportunity to be of service to you and wish to express our appreciation for the confidence extended by your selection of **Reinco** mulching and seeding equipment.

WHAT IS HYDROGRASSING?

HYDROGRASSING has emerged as one of the most practical methods of establishing ground cover, particularly on slopes and difficult access areas. Because of the varied slurry capabilities, prepared ground surfaces can be covered in a single pass, thereby realizing a significant labor savings. With optional equipment and accessories, and a variety of amendments available, the process has become popular for establishing turf for large area landscape construction to small residential and maintenance applications. Machine sizes vary to accommodate a variety of tasks.

In basic concept, HYDROGRASSERS are mobile slurry generators, which satisfy the needs of professional landscape or reclamation contractors. The concept of hydraulic grassing was researched by the Connecticut Department of Highways prior to World War II. Thereafter, developments followed making the technique more practical.



The early units combined earth, peat, seed and water to produce slurry, which was then applied to prepared seedbeds and slopes from an elevated platform utilizing a boom and spray nozzle mechanism. This seeding process has evolved to a degree to which the industry is now highly committed.

It is our understanding, that these original units employed a diaphragm mud pump to develop spray pressure with a separate propeller blade mixer installed to agitate the granular solids. Each had its own gasoline engine drive resulting in a cumbersome and maintenance prone arrangement requiring skilled and highly trained operators.

The present day REINCO HYDROGRASSER is very different from the early prototypes. Gone are the multiple engines, the antiquated horizontal agitators and the necessity of having a master mechanic's background for operational reliability. Simplicity, without sacrificing performance, has been Reinco's prime development concept over the years. This credo has proven its merit since the first hydraulically agitated seeder was built back in 1960.

Combining the exclusive jet driven mulch grinder and multi flow action of the blenders, materials are charged and dispersed quickly into uniform slurry.

Reinco's exclusive HYDRO-JET mixing system generates powerful and concentrated streams of water supplied from a common mixing manifold. These streams continuously flush over and across the tank bottom carrying the entrained materials up to the surface and then drift downward; thereby producing well distributed homogeneous slurry. The benefit to be realized, in addition to performance, produces dividends year after year with reduced maintenance.

The mulch grinder shred packed materials into small chunks then throws these materials across the slurry surface. The upper level multi flow blenders then draw the materials from the surface while simultaneously lifting the slurry over the floating materials to wet and disburse into the mixture. The lower blenders act to lift the slurry materials from the tank bottom to further incorporate these materials into a homogenous mixture.

To provide a sense of productivity, the HG-13GX carries a nominal rating of 1/3 acre per hour (One Step method) based on usual fiber mulch rates.

Depending on mulch requirements, using processed fiber, this machine will have up to 14,500 sq. foot coverage potential. This rating includes charging, mixing, transporting and discharge (application) times, at distances up to 130 ft. effective slurry coverage (400 ft. with optional remote spray hoses).

The 1300-gallon working volume alternately offers effective coverage is up to 2 -1/3 acres without the addition of fiber mulch (Two Step method).

The HG-13GX HYDROGRASSER can be used for tacking over hay or straw mulched jobs, as well as remote watering of newly seeded and landscaped areas. Patch-up or reworked washouts can be effectively handled.

SAFETY

HYDROGRASSER SAFETY OVERVIEW

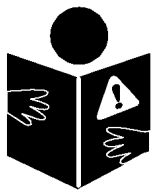

Personnel responsible for your Hydrograsser training program, maintenance, and operations must read and understand this safety manual and operator's manual. No one should set up, operate or maintain a Hydrograsser until they understand it, its operation and know how to do their job safely.

RECOGNIZE SAFETY INFORMATION



This is the safety alert symbol. When you see it in your operations manual be alert to the potential for personal injury.

Follow recommended precautions and safe operating practices.

UNDERSTAND SAFETY WORDS

A signal word - **DANGER**, **WARNING**, or **CAUTION** is used to identify a potential for serious injury. **DANGER** identifies the most serious hazards.

DANGER or **WARNING** safety signs are located near specific hazards. General precautions are listed on **CAUTION** safety signs. **CAUTION** also calls attention to safety messages in this manual.



FOLLOW SAFETY INSTRUCTIONS



Carefully read all safety messages in your operations manual and on your Hydrograsser. Keep safety signs in good condition. Replace missing or damaged safety signs. Be sure new equipment components and repair parts include current safety signs and safety guards. Replacement safety signs and guards are available from your Reinco dealer or directly from Reinco.

Learn how to operate the machine and how to use the controls properly. Do not let anyone operate without instruction.

Keep your machine in proper working condition. Unauthorized modifications to the machine may impair the function and/or safety and affect machine life.

If you do not understand any part of this manual and need assistance, contact Reinco directly.



800-526-7687

CONCENTRATE ON YOUR JOB

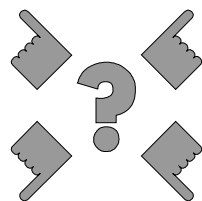

Daydreaming, worrying about other problems or other improper operation of a machine could cripple you for life. Operating a Hydrograsser requires your complete attention. Talking, joking, participating in, or watching horseplay could result in physical injury to you . . . and that is not something to joke about. So, watch what you are doing and concentrate on your job.

KEEP CLEAR OF THE WORK AREA

The purpose of a Hydrograsser is to mix and distribute slurry of seed, fertilizer, lime, processed mulch and other amendments, away from the machine. The Hydrograsser utilizes engine power to drive a pump to mix and process the materials into uniform slurry. It is obvious that this same capacity will sever arms, hands, fingers or any other part of the body that is in the work area when the machine is activated.

Additionally, the discharge from the blower is capable of discharging the processed slurry at high velocity (more than 160 feet on some models). The discharge of the machine is powerful enough to dislodge pebbles, stones or other debris, which may cause eye or personal injury.

The person responsible for activating the machine is the boom operator. It is his responsibility to see not only that his own body is clear of the work area and all moving parts, but that his co-workers are clear also and are entirely visible in a safe location before activating the machine.



During set-up, maintenance or other work on the machine, which requires manipulation within the tank, engine or other work area, the key should be removed from the machine and the battery disconnected.

WEAR PROTECTIVE CLOTHING

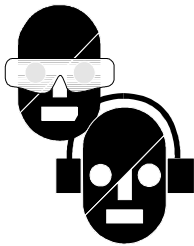

Protect your eyes from blowing chaff, as well as other foreign debris, which may be found in the materials to be mixed. Use approved impact resistant eyewear.

As the conditions dictate, the use of respirators to protect you from inhaling nuisance dust is recommended.

Construction equipment is noisy. Prolonged exposure to loud noise can cause impairment or loss of hearing. Use approved ear protection to control this hazard.

Reflective gear and hard hats may also be necessary depending on your job site.

PRACTICE WORK AREA SAFETY RULES

The location of your job site will demand that additional safety practices be implemented. Always follow the applicable OSHA regulations.

While working on roadsides and interstate highways, insure that appropriate strobes, flashers and other warning devices are installed on all vehicles as required by law. All workers should be wearing high visibility reflective vests. Anti-crash vehicles should be employed when appropriate. The use of barriers and flagmen is suggested. Be aware of the traffic flow and use caution to avoid discharging towards vehicles.

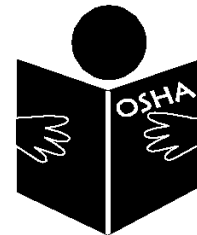

Since Hydrograssers are used at a variety of locations (strip mines, coal storage areas, land fills, refineries, power plants, and protected wilderness areas) it is imperative to contact the appropriate safety official or regulating agency to obtain information regarding any special safety considerations on specific job sites.

FIRE IS ALWAYS A POSSIBILITY

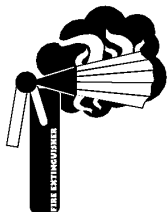

The potential for fire always exists. The combinations of fuels, heat from engines, fertilizers, mulch materials, and packaging will increase the risk. Have a fire extinguisher near the work area. Learn to look for it before you begin working. Always keep the machine clean of chaff and debris.

NEATNESS IS IMPORTANT



Keep the floor of your work area clear of bales or flakes of mulch, twine, scrap and trash that could cause you to stumble. Falling or slipping can result in painful or perhaps even fatal injuries.

Put all fuel, tools and other equipment away when you are not using them. Even a screwdriver can be deadly if left on an enclosure of the machine.

CLEAN AS YOU GO !

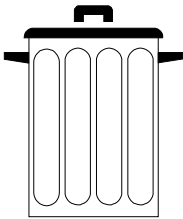

Twine, when removed, should be disposed of immediately in a container away from the Hydrograsser. That loose piece of twine or debris around the machine could cause you to fall or lose a hand or finger.

PROPER BALE HANDLING IS IMPORTANT

Bale packaging can be dangerous. When cutting and removing the packaging from a mulch bale the handler must make sure that the debris is not pulled into the machine.

Bale twine can wrap around a shaft and pull an arm or hand into the machine. It is capable of cutting through fingers.

It takes only a fraction of a second to lose fingers. Pay attention to your fingers, the twine, and the moving equipment when handling twine.

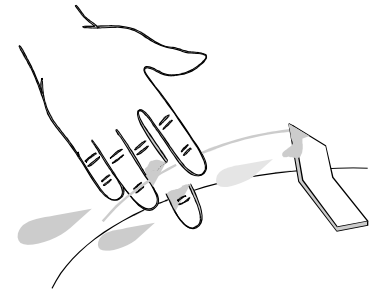

VIBRATION IS A WARNING SIGN



A rotational unbalance of any sort will become obvious in the form of vibration. Vibration is an important warning sign of impending mechanical failure. Instruct all users of your equipment to report unusual vibration at the onset.

PRACTICE SAFE MAINTENANCE

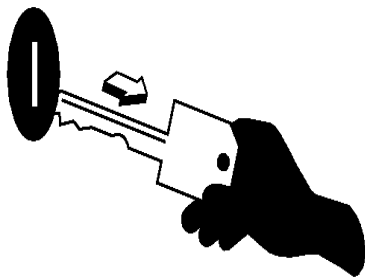

- Understand service procedure before doing work.
- Keep areas clean and dry.
- Keep clothing away from moving or power driven parts.
- Disengage all power and operational controls, and relieve pressure.
- Stop engine and remove key. Allow engine to cool down before working on any engine component.
- Disconnect the battery before machine adjustments or welding on machine.
- Keep all parts in good condition and properly installed.
- Fix damaged components immediately.
- Replace worn or broken parts.
- Remove any build-up of grease, oil or debris.

PROPER ENGINE SERVICING IS IMPORTANT

Do not perform service on an engine if you are not qualified.



Use care when refueling the engine. Fuels and their vapors are extremely flammable and may explode when ignited. Do not fill the fuel tank while the engine is hot or running, since spilled fuel may ignite if it is exposed to hot parts or sparks from the ignition.

Do not start the engine near spilled fuel; wipe up spills immediately.

Never use fuel for a cleaning agent.

Store fuels in approved containers only. After refueling, remove any containers from the immediate work area.

Do not add oil when engine is hot or running as oil may vaporize and ignite.

Do not add coolant to water-cooled units when engine is hot due to the possibility of steam burns. Only remove filler cap when cool enough to touch with bare hands. Slowly loosen cap first to relieve pressure before removing completely.

Engines are a burn hazard. The crankcase, cylinder head, exhaust system, radiator, and other components can get extremely hot from operation.

The electrical systems of engines can be a source of high voltage. Never touch electrical wires or components when engine is running.

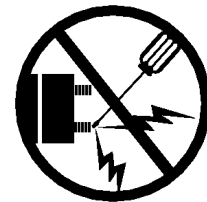

Never attempt to start the engine by shorting across the starter solenoid.

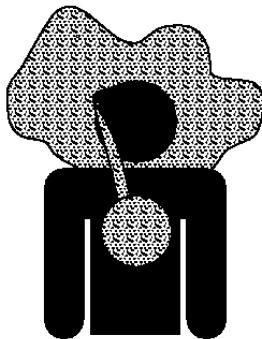

Engine exhaust gases contain poisonous carbon monoxide. Never run engine in an enclosed area. **Avoid inhaling exhaust fumes.**

Avoid accidental starts, which could cause injury to you or fellow workers. **Remove the ignition key when servicing the unit.** Disconnect and ground the spark plug wire on one or two cylinders. On electric start units, disconnect the battery cables. Always remove the ground (-) cable first.

Refer to the engine manufacturer's operation and safety manuals for more detailed information.

ENGINE SPEED IS IMPORTANT

Never tamper with the governor component settings to increase the maximum speed. The components used to build the Hydrograsser are designed to operate at a specific maximum speed. Severe personal injury and damage to the Hydrograsser can result at speeds set above the maximum. A rotation unbalance of any sort will become obvious in the form of vibration. **Vibration is an important warning sign of impending mechanical failure.** Notify your supervisor of any unusual vibrations or noises at the onset.

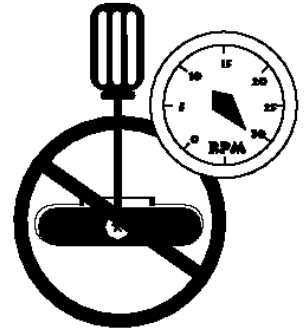

DISPOSE OF WASTE PROPERLY

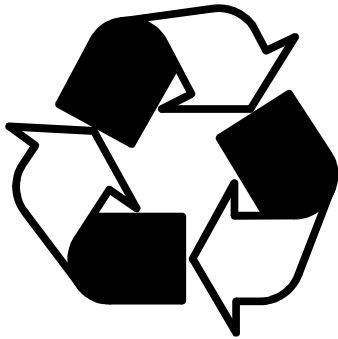

Improperly disposing of waste can threaten the environment and ecology. Potentially harmful waste associated with Reinco equipment include such items as oil, fuel, coolant, filters, batteries, emulsified asphalt, tackifier and fertilizers. Bale packaging or twine should be disposed of in appropriate containers.

Use labeled, leak proof containers when draining fluids. Do not use food or beverage containers that may mislead someone into drinking from these. Do not pour waste onto the ground, into a drain or into any water source.

Inquire on the proper way to recycle or dispose of waste from your local environmental or recycling center, or from your state's Environmental Protection Agency.

LOOK THINGS OVER CAREFULLY

Before operating your Hydrograsser, look to see if your machine is in the proper condition. Is the workspace clean? Is the fuel properly stored? Is all the bale packaging cleaned up? Are the machines guards and covers all in place? Are all nuts, bolts and screws tight? Do you know where the fire extinguisher is? Do all workers have protective safety gear? Is everything in proper operating condition? If not, report the unsafe condition to your supervisor and be sure the problem is corrected before beginning operation.



KNOW YOUR MACHINE

The Hydrograsser has one characteristic in common with most machinery. Do not assume that simply turning off the machine will insure that all moving parts have stopped. The moving machinery can cause serious injury and even death. Be aware that a shaft, which rotates at speeds exceeding 2000 revolutions per minute, is extremely dangerous.

1. Before operating this machine, be sure to read this entire manual.
2. Do not operate unit if unfamiliar with operational and safety procedures on this or any unit.
3. The force from the discharge can kick up dust, dislodge unsecured items and damage property.
4. Never discharge the unit towards people. Bodily injury may occur.
5. Never force any material into the machine.
6. Never attempt to clear the machinery of debris or make adjustments while the engine is running.
7. Be sure to keep all body parts and clothing away from moving parts while engine is running.
8. Do not attempt to mix or discharge rocks, nails, or other debris, which may damage the machinery or cause premature wear.
9. Do not operate machine without required coupling, shaft, or bearing guards installed.
10. Materials packaging must be removed carefully to prevent being pulled into the machine.
11. Do not allow fingers to become entangled in the bale twine or packaging.
12. Do not wear loose clothing, which may become entangled with the machinery.
13. Do not add oil, water or fuel while engine is running or hot.
14. Do not perform maintenance while unit is running or battery is connected.
15. Do not under any condition operate the machine when vibrating.
16. Working space must be allowed not only for the machine operator, but also for access to the stacked materials.
17. Daily, inspect the machinery for signs of wear. Do not operate the machinery until problems have been remedied.
18. Always make sure fittings are secure and valves are operational and in good order.
19. The pump impeller is made of cast iron. If a vein breaks, or is clogged with debris an unbalance or vibration will occur. Do not under any condition operate the machine when vibrating.
20. Check the agitating jets and fittings for wear. The granular nature of materials used will abrade and enlarge the nozzles causing a noticeable reduction in mixing and discharge pressures. Rocks and foreign matter found in some materials may clog the nozzles or pump impeller and cause noticeable reduction in pressure or vibration.
21. Secure the discharge boom and hose(s) before transporting the machine.
22. **IT IS IMPERATIVE THAT COMMON SENSE AND GOOD JUDGMENT BE EMPLOYED WHEN OPERATING THIS MACHINE.**

CHEMICAL REACTIONS

With the wide variety of Hydrograssing amendments available, it stands to reason that all may not be compatible.

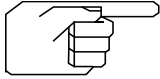

CERTAIN FERTILIZERS REACT WITH LIME PRODUCING FREE AMMONIA.

Wetting agents may cause foaming. Binders may agglomerate (stick together) because of the minerals in the water. Foaming and aeration are visible conditions that point to material problems.

AERATION

This is not a chemical problem, but does affect pump performance. Too much air getting into the water will cause vapor blocks and consequent erratic pumping. The obvious cause is over agitation. Simply slow down the engine. Extremely light granular loads or low tank levels contribute to entraining air in the suction line and pump casing.

FOAMING

Excessive bubbles and froth point directly to this. The problem is that the pump has a reduced efficiency to move liquid because of vapor blockages and the impeller vanes cannot properly pump out. One solution is to add corn oil to the mix. Add a 1-quart to 500-1000 gallons depending on degree of foaming.

However, the materials suppliers should be contacted to establish a cause and offer recommendations.



DANGER! CERTAIN AMENDMENTS, WHEN COMBINED WITH OR WITHOUT THE ADDITION OF WATER OR HEAT OR THE ELEMENT OF TIME, MAY REACT CAUSING HARMFUL OR DEADLY GASSES! CONSULT YOUR MATERIAL SUPPLIERS REGARDING REACTIVITY INFORMATION

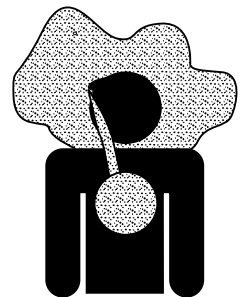

OPERATION

MACHINE DESCRIPTION

The model **HG-13GX REINCO HYDROGRASSER** is a self-contained, multi-purpose machine comprised as follows:

1. **PUMP/ENGINE** combination, consistent with unit capacity and spray range.
2. **SLURRY TANK**, sized to contain the rated slurry payload in what is termed "swept volume". The tank is engineered to function integral to the mixing scheme.
3. **MULCH GRINDER/BLENDER**, hydro-jet driven assembly is **VERTICALLY SUPPORTED IN THE TANK**. The 'Multi-flow Quad Blenders' extending from beneath the grinder wheel will create a vortex effect, drawing dry materials from the slurry surface and simultaneously pulling materials upward from the tank bottom, to immediately incorporate those materials into the agitation jet turbulence.
4. **CIRCULATING MANIFOLD ASSEMBLY**, incorporating cast iron **HYDRO-JET** agitating nozzles. Grooved piping connections allow for simplified maintenance.
5. **SPRAY SYSTEM** including boom, nozzles, and control valve for dispensing the slurry. The boom discharge swivel allows a 360-degree horizontal and vertical movement for controlled placement. Hose reel, remote spray hoses and spray bars add versatility.
6. **BASE FRAME/TRAILER ASSEMBLY**, serving as a mount for the foregoing components.
7. **FILL ASSEMBLY**, providing an anti-siphoning connection to prevent contamination of the source water. A quick-disconnect style fitting is provided to connect fill hoses. The fill assembly is provided with full flow ball valves to allow ground level as well as tank top control. A garden hose bib is provided to utilize the fill water source for wash down.

MOUNTING

The skid mounted **HG-13GX REINCO HYDROGRASSER** can be secured to any flatbed truck or trailer and is compact enough to be carried on a 12-foot platform body. The unit must be located so that when charged, the weight is evenly distributed on the vehicle. When mounting the unit, a truck of adequate Gross Vehicle Weight (GVW), and proper Cab to Axle (CA) dimension should be used to get the desired handling capability. This information is listed in the respective specification bulletins. Consideration must also be given regarding specific options installed. It is equally important to locate the **HYDROGRASSER** on the truck correctly, taking into account "DEAD" and "LIVE" load weights to satisfy acceptable axle loading.

A front-end loader, a forklift or gantry with lifting chain or sling, can be used to lift and position the machine. The center point of the lift rings welded to the tank, more or less, indicates the empty (dead weight) center of gravity. (Inclusion of the remote hose or hose reel option will offset that center, toward the boarding end of the unit, causing the machine to tilt when raised by crane). Ideally the empty center of gravity should be approximately 3"-6" forward of the vehicle's rear axle when the **HYDROGRASSER** is in place. When the tank is full (live load), the center of gravity moves forward (toward the cab of the truck). Proper positioning must consider this. Additional space must be provided for any additional options. Consult your truck dealer for specific axle and spring loading information. Chains looped over the ends of the base frame and tensioned with binders, is perhaps the most practical way to temporarily secure the machine to the truck bed while transporting the empty unit only. Once in place, secure with binders or mounting cleats and blocks.



IMPORTANT! Insure that the machine base is placed on a level surface before fastening. Do not distort the machine frame when binding.



Federal guidelines (FEDERAL Motor Vehicle Safety Standards) mandate strict requirements when mounting machinery on truck frames for over the road use. Installation of this HYDROGRASSER requires a Completed or Altered Vehicle Certification sticker issued by the installing dealer.

PRE-OPERATION INSPECTION

Every machine is tested for performance and checked for quality before shipment. Inspection at the factory includes wet testing for range and system pressures, setting of engine throttle "under load", and inspection of the pump drive coupling and alignment; engine fluid levels and pump seal adjustment. Wet-test readings are recorded. Machines are then drained and prepared for shipment. Cold weather precautions are also taken (see pg39.). Keys for starting the unit are usually included with the operations manual for safe keeping during shipment. Although each machine is packaged for near immediate operation and is tested at the factory prior to shipping, retrace the factory inspection procedures before starting.

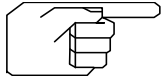

Initial pre-starting inspection requires tracing the steps taken at the factory, Additionally, recheck those items as outlined:

- Crankcase Oil Level
- Engine air cleaner assembly
- Fuel [check engine manual for proper grade]; provide sufficient fuel for startup.
- Throttle and choke controls
- Check battery terminals and connections
- Inspect tank for debris-remove before starting machine.
- Check hydraulic system oil level.
- Check hydraulic system for leaks.
- Inspect piping and hose connections.
- Inspect discharge components and connections.
- Check screws/fasteners for tightness
- Inspect all bearings, set screws and locking collars.

ENGINE BREAK IN

The BREAK-IN period for the specific engine is noted in the vendor operation manual supplied with each new unit. Proper engine break in and maintenance scheduling will result as increased engine life.



IMPORTANT! Follow manufacturers' recommended first and consecutive oil and filter changes.

START UP



CAUTION! BEFORE starting engine, familiarize yourself with this entire manual. Also, read the engine manual.

Before starting the unit, be sure it is mounted as described previously. Be sure to make your test run in an open area.



CAUTION! Force from the discharge can kick up dust and blow over items that are not secure.

After reading the engine manual, you may start the engine.

The **diesel engine** is provided with a keyed ignition star switch with a timed preheater switch. Turn the key to the left momentarily, or until the timer lamp shuts off, and then turn the key to "start". Adjust the throttle to run smoothly as the engine warms up.

When running smoothly, adjust the throttle to a high idle. No strange noises or vibrations should occur. If there is, shut the engine down and rectify the problem (See MAINTENANCE AND SERVICE). For break-in procedure, refer to the vendor Engine Manual for details.

The engine is provided with instrument lamps including oil pressure, coolant temperature and alternator circuit. These lamps may illuminate for a short time while starting the unit. If either of the lamps remains illuminated, shut down the engine, identify the cause and correct before continuing to operate the unit.

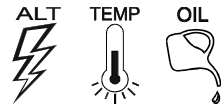

A governor control is set at the factory for 2600-RPM maximum throttle extension under load. The throttle is a vernier type. Depressing the center button and pushing or pulling makes quick adjustments. Releasing the button will lock the control, and by rotating the outside knob, a fine or vernier variation occurs. A tension-locking device is provided to maintain the desired operating speed, when desired.



Be sure all operators read and understand the following operational precautions:

OPERATING CAUTIONS

1. **Materials packaging should be cut and removed to prevent loose trailing ends from wrapping around fingers and then being pulled into the rotating areas of the machine.**
2. **Never attempt to clear debris or make adjustments while the engine is running.**
3. **Check the pump seal lubricator at regular intervals during operation.**
4. **Routinely inspect the drive coupling connecting the engine drive shaft to the pump shaft. Wear on the center member or coupling looseness will result from a vibration situation caused by an imbalance or misalignment due to overloading, obstruction or frame distortion (see Mounting). Do not operate the unit until the coupling has been aligned or repaired.**

ENGINE OPERATING CAUTIONS

1. **The engine has been set to a maximum operating speed of 2600 RPM under load. Do not exceed or set speed higher, as wear from excessive vibration may occur.**
2. **Clean chaff and debris from engine and radiator screen routinely. Clean the radiator cooling fins on a periodic basis.**
3. **The engine is intended to run in a level position. Intermittently, the engine may run at a maximum of 25° angle for not more than 10 minutes.**
4. **The available horsepower supplied by the engine drops approximately 3% per one thousand feet above sea level. When operating unit at an altitude of 5000 feet or greater, consult local engine service representative.**

Familiarize yourself with this entire manual. Also, read the engine manual.

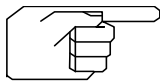

Fill tank approximately one third full with water for your trial run. Make sure the discharge connections are secured and all valves are in their off position.

After reading the engine manual, you may start the engine. Before starting the unit, be sure it is mounted as described previously. Be sure to make your test run in an open area.

Move throttle 1/4 of its travel. Start by turning the ignition key to the right and hold momentarily until the engine starts. After starting, slowly reposition the choke to the fully open position. If vibration or roughness exists, stop engine and check for the cause.

Once the engine has warmed up and everything appears in order, set the throttle for maximum speed. Run for a short period then reduce the speed to a slow idle, allowing the engine to cool. Turn the engine off.

If the machine runs smoothly, proceed to operation section of this manual. If no irregularities are noticed, the unit is mechanically ready for a trial fill. Should problems arise at this point, refer to maintenance section of this manual.

TRIAL RUN

The following steps should be followed for the first run to familiarize operators with the **HYDROGRASSER**:

1. READ THIS MANUAL IN ITS ENTIRETY.
2. Make sure the drain plugs and manifold cap covers are in place and secured.

It is worth noting the following with regards to filling:

3. Utilize the fill assembly to prevent siphoning back into the water supply.
4. Never fill through the remote spray or hose reel hoses.
5. Many hydrant systems contain small rocks or pebbles, which may contribute to plugging the machine.
6. Always use a hose end strainer when filling from ponds or streams.
7. Make certain that the spray and grinder valves are turned to the off position before starting unit.
8. Check engine fluid levels. Fill as required.
9. Start the engine. Run at moderate idle until warm then rev up to half throttle.
10. Inspect the operation of the **HYDRO-JETS** by raising the hatch cover/load tray and peering through the hatch. Make sure the jets are spewing a solid stream of water. If this is not the case, stop the engine and check for obstructions.
11. Inspect the operation of the **GRINDER/BLENDER** assembly by opening the control valve. Observe the blender operating in the tank. The blender should spin freely. If this is not the case, close control valve, stop the engine and check for obstructions.



DANGER! KEEP BODY AND CLOTHING CLEAR OF GRINDER ASSEMBLY WHILE IN MOTION SEVERE INJURY MAY OCCUR!

12. Reduce engine rpm then turn the engine off.
13. The **HYDROGRASSER** is equipped with a platform spray boom assembly. Install the spray return loop (J-pipe) to nest over the top of the spray boom swivel joint assembly.
14. Select one of the spray nozzles and install it into the female quick coupling on the end of the spray boom. There is a sealing gasket in the seat of the quick coupling. Make certain it is in place or the connection will leak.
15. Verify that the spray valve is in the off position and that the spray nozzle is secure. Then restart the engine. After an adequate idle, bring up the engine throttle. Fully open the spray valve. Articulate the spray to judge the range and pattern of the nozzle. Then vary the throttle to observe how changes in engine RPM effect spray range. Repeat this procedure with the other nozzles supplied.
16. Resume filling machine with water. Prepare to add materials to the unit by becoming acquainted with the **GRINDER/BLENDER** system.
17. Adjust the engine to moderate to fast throttle, and adjust the blender control valve so that the blender is revolving with maximum speed and power. Adjust the blender speed to keep the water moving at a fast stir.
18. While standing on the spray platform, place a bale of fiber mulch on the load tray. Cut, remove, and discard the packaging material from the bale of mulch. Be certain **not** to allow packaging material to fall into tank!

19. Break up the bale and drop segments into the rotating path of the grinder. Most mulch materials are drawn down and mixed into the slurry quickly. Depending upon mulch materials and slurry amendments, mixing times may vary.



DANGER! DO NOT STAND ON THE TANK TOP WHILE OPERATING THE MACHINERY. SEVERE INJURY MAY OCCUR!

20. Add a subsequent bale of fiber mulch. Adjust the blender speed as necessary to compensate for the increasing thickness of the slurry. Two bales should be more than enough to get an idea of the speed and function of the blender system. It is important to be aware of the amount of water in the tank when loading mulch. Since each bale will require approximately 100 gallons of water to properly slurry (*Mix Preparation* pg.21), care must be taken not to put more mulch into the tank than the water level will allow.
21. Turn off the grinder/blender supply valve to observe the slurry. The tank may now be emptied by either spraying the load out or by shutting the engine off and then draining the tank by opening the drain cap (item 4, pg.50) located on the sump.
22. A partial fill of clear water can be charged to facilitate cleanup before storing the machine.
23. Remember these important operational procedures when using the **HYDROGRASSER**:

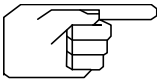

IMPORTANT! BE AWARE OF WATER LEVEL WHEN LOADING MULCH DO NOT ATTEMPT TO LOAD MULCH WITHOUT SUFFICIENT WATER TO MAINTAIN SLURRY FLUIDITY.

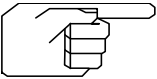

IMPORTANT! KEEP BODY AND CLOTHING CLEAR OF BLENDER WHILE IN MOTION AS SEVERE INJURY MAY OCCUR.

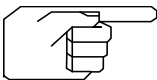

IMPORTANT! SPRAY VALVES MUST BE FULLY OPEN OR CLOSED. PARTIALLY OPEN VALVES WILL QUICKLY WEAR OUT.

(Although contrary, hose valves may be throttled, as periodic replacement costs of the valve outweigh the cost of another man stationed at the machine to control the engine throttle).

MIX PREPARATION

The most frequently asked question of the unseasoned operator is: "What to put into the tank? How much coverage can be expected?" Both are redundant since specifications, either formal or self conceived; determine the amounts to be mixed. Amendments may include seed, inoculants, and fertilizer. It is highly unlikely that all would go in simultaneously because of capacity limitation and/or incompatibility.

Capacities are based upon each *100 gallons (of water)* working volume, as follows:

*WATER CAPACITY = 100 GALLONS WORKING VOLUME.
GRANULAR SOLIDS CAPACITY (SEED, FERTILIZER, LIME) 25-40lbs.*
PROCESSED FIBER MULCH = 40-50 lbs.
Reinco TRACER™ TACKIFIER) = 3/4 lb.*

**Check specific model specifications*

Noting that these ratings are established for the machine's ability to handle these materials in quantities based on 100 gallon increments, the machine is sized by its 'Working Volume' of water, also based on 100 gallon increments.

The ratings establish the amount of water by which the other amendments are determined for the purpose of batch sizing. The machine total area provides an approximate 20-25% 'freeboard' to accommodate the displacement of the materials added to the water volume. For example, a 1000 gallon **Hydrograsser's** 'Swept (total) Volume' is then rated at 1250 gallons of *combined slurry* capacity.

The Hydrograsser agitation scheme offers high granular capacities, however, it should be realized that these granular products will promote wear of the pump impeller as well as the mixing jet and piping components. For extended life of these components, it is advisable to source fertilizers with a minimum of fill materials (granulated rock). Liquid fertilizers and liquid limes are available alternatives; however, job specifications should be consulted.

Processed fiber mulches and **tackifiers** are rated separately from the granular solids capacity, as these amendments require absorption of water to produce pumpable slurry. Although the inclusion of these materials will not affect the granular capacity of the machine, the capacity of the machine to handle these materials will limit the batch sizing quantities of all materials. Variations of materials, including the quality of the materials will dramatically modify the capacity ratings. Debris introduced either in the material or accidentally, will reduce performance.

The table following this section will assist in determining tank load requirements based upon the type of mulch used, and its capacity to absorb water in the slurry process. It is more advantageous to round up the number of tank loads and distribute the material requirements evenly, than to attempt to overload the machine.

HYDROGRASSING

STRAIGHT HYDROGRASSING

Straight Hydrograssing (commonly called the '*TWO STEP METHOD*' or '*THREE STEP METHOD*') is based on typical highway specifications. This procedure (1) places the seed, fertilizer and water slurry directly onto the prepared seedbed, insuring contact with the soil surface. The application is routinely followed with applications of mulch (2), blown either straw or hay, with a final application (3) of tackifier slurry insuring the placement of these materials, or processed fiber mulch and tackifier. A seasoned operator can effectively cover an acre with 500 gallons of prepared slurry. This means that the model **HG-13GX3 can be used to seed up to 2-1/3 acres**, with the following sample charge:

Amendments Per Batch

Seed @ 150 lbs/Acre x 2.3 (K31, Fescue, Rye mix)=345 lbs.

Fertilizer (10:10:10, 45# N²) @ 450 lbs/Acre=1035 lbs.

TOTAL GRANULARS= 1380 lbs.

In this example the 3100lbs. granular solids capacity is not compromised and a single batch is capable of the full 2-1/3 acre coverage.

For *Straight Hydrograssing*, the batch quantities are calculated on a "500 gallons of slurry per acre" requirement, and adjusted for the machine capacity. A 1000 gallon working volume would then equal 2 acres, a 1500 gallon working volume 3 acres, 2000 gallon working volume 4 acres, and a 3000 gallon machine at 6 acres.

STRAIGHT HYDROGRASSING WITH LIME

In many areas of the country, and particularly in mine reclamation work, heavy quantities of lime may be specified. Frequently lime must be applied first and then incorporated into the soil before seeding and fertilizing. It is not uncommon to distribute lime at one to two tons to the acre or even more. However, it becomes impractical to apply much larger quantities of lime, via the hydraulic seeding method, due to the abrasiveness of the product. Consult your materials supplier regarding pumpable grades and analysis.



**IMPORTANT! USE ONLY FINELY GROUND PULVERIZED LIME STONE.
DO NOT USE COARSE AGRICULTURAL PRODUCT OR HYDRATED LIME.**

How would the proportions, in the preceding example, be affected by the additional requirement of 2000 pounds of lime per acre? Since it was determined that the maximum fiber that could be charged would cover just over one third acre, the corresponding proportion of lime would be 700 pounds.

This brings the total granulars to 912 pounds, or well below the unit's 3100 pound rating. Therefore, the mix quantities do not exceed the machine's capacity and are acceptable.

Amendments Per Batch

Seed @ 150 lbs/Acre x 1 (K31, Fescue, Rye mix) =150 lbs.

Fertilizer (10:10:10, 45# N²) @ 450 lbs/Acre =450 lbs.

Lime @ 2000 lbs./Acre x 1=2000 lbs.

TOTAL GRANULARS=2550 lbs.

HYDROGRASSING WITH PROCESSED FIBER

Appropriately referred to as the ' ONE STEP METHOD', this procedure places all of the ingredients on the prepared seedbed simultaneously. The fiber mulch and tackifier are incorporated into the slurry mix and broadcast in a single application. Ideally suited to small areas where a sterile (weed free) application is preferred, the limitation is that the application will require multiple batches to cover a relatively large area. Fiber, whether paper, cellulose, virgin wood or combinations thereof, are not considered granular solids. It is important to realize, however, that when using fiber mulch, the mulch becomes the limiting factor in the loading equation. Usually 40-50 pounds of a good fiber requires about 100 gallons of water to produce pumpable slurry. Application rates can sometimes exceed 2000 lbs per acre. Consider a fiber application rate of 1500 pounds/Acre; the tank load capacity would be 500 lbs., with approx. 14,520 sq. ft. (1/3 acre) coverage. Again, using the previous seed and fertilizer mix ratios calculate the 1/3 acre batch adjusted to the fiber application rate.

Amendments Per Batch

Seed @ 150 lbs/Acre x .43 (K31, Fescue, Rye mix) = 65 lbs.

Fertilizer (10:10:10, 45# N²) @ 450 lbs/Acre x .43= 194 lbs.

Fiber @ 1500 lbs./Acre x .43= 650 lbs.

Reinco TRACER™ Tackifier @ 5 lbs./Acre x .43= 2.15 lbs.

Now consider the same fiber application rate of 1500 pounds/Acre; and the tank load charging capacity at 400 lbs., with approx. 12,000 sq. ft. (1/4 acre) coverage. Adjust the tank load requirements using the previous seed and fertilizer mix ratios calculate a .1/4 acre batch, adjusted to the fiber application rate.

Amendments Per Batch

Seed @ 150 lbs/Acre x 1/4 (K31, Fescue, Rye mix) = 37.5 lbs.

Fertilizer @ 450 lbs/Acre x 1/4 (10:10:10, 45# N²) = 112.5 lbs.

Fiber @ 1500 lbs/Acre x 1/4 = 400 lbs.

Reinco TRACER™ Tackifier @ 5 lbs/Acre x 1/4 = 1.25 lbs.

Fiber mulch application and charging rates, therefore, will now determine the coverage area per tank load. At a fiber rate of 1500 lbs. per acre an additional tank load would be required for the lower charge rate.

The '**ONE STEP METHOD**' is suited to areas where irrigation (or ambient moisture) is not an issue. Because seed remains suspended in the mulch layer, moisture must be adequately controlled to insure germination and sowing. Applications that require heavy mulch applications will often suspend the new seedling out of the seedbed, and result in a failed application if moisture is not maintained. Most experts will agree that this method is never recommended for slope applications, regardless of tackifier ratios. As the mulch materials biodegrade, the vegetative stand controls the soil moisture by inhibiting the surface evaporation. If the root structure is not sufficient reach subsurface water the vegetation will fail without supervised irrigation.

THE 'MODIFIED' ONE STEP METHOD (1SMM)

This method originates from DOT regulations requiring assurance of seed contact with the soil. All of the amendments for the slurry are mixed and sprayed with a trace amount of fiber mulch for gauging. Subsequently, batches of fiber mulch and tackifier only (hydromulching) are applied over the previously seeded area. This process is ideal when the site prep work has been completed and the landscaper wants to seed the entire area quickly. Given the granular capacities of most machines, up to one acre or more can be seeded for each 500 gallons of water capacity (working volume). The 'hydromulching' of the areas can be done in the batches following the initial seeding. Overall, productivity and costs are slightly more than the 1SM.

Advantages are:

- 1) Seed and fertilizer can be batched for the machine's full capacity.
- 2) Broadcasting occurs over a large area quickly
- 3) Minimal soil/seedbed disturbance
- 4) Over spraying dissipates mulch application water requirements eliminating rills and puddle formation.
- 5) Mulch applications are more effective when applied in layers minimizing slump and runoff from operator misapplication.
- 6) Stronger, healthier vegetation with less supervision

HYDROGRASSING WITH FIBER & LIME

How would the proportions, in the preceding example, be affected by the additional requirement of 2000 pounds of lime per acre? Since it was determined that the maximum fiber that could be charged would cover just one third acre, the corresponding proportion of lime would be 670 pounds. This brings the total granulars to 822 pounds, or well below the unit's 2500 pound rating. Therefore, the mix quantities do not exceed the machine's capacity and are acceptable.

HYDROGRASSING WITH BFM (FIBER MATRIX MATERIALS)

BONDED FIBER MATRIX PRODUCTS are comprised of a hydroseeding type of mulch, paper, wood, or combinations, with high volumes of 'bonding agents' (Tackifiers). The BFM provides an effective alternative to blanketing and other methods where erosion control methods are critical, and applications are difficult or not easily accessible. BFM's are specified where soil or silt erosion cannot be tolerated. The 'matrix' is created by applying the material in a stacking manner, where a high-density interlocking mat is formed, thus controlling the moisture at the seed germination zone. It is preferable to apply the materials with minimal disturbance of the prepared soil texture.

Usual applications require that the seed and granular materials are applied as with the 1SMM (Modified One Step Method) to assure seed to soil contact. Effective densities of the matrix mixtures are dependent upon operator capability.

Mechanically bonded materials include synthetic fibers materials, with tackifier added for water holding capability. Mechanically bonded materials will require minimal or no curing time, dramatically improving application cycle times.

BFM material application rates are usually very high, by comparison to standard hydroseeding applications. Applications of 2000 to 4000 lbs. per acre are usual for critical areas and will vary with erodable water velocity predictions.

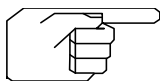

CAUTION Certain tackifiers, when used in high volumes, may cause erratic pumping. The pump speed must be slowed to remedy this condition. Consult your material supplier for recommendations.

FIBER MULCH LOAD RATE COMPARISONS

EQUIP WATER VOL.	MULCH REQ'D PER ACRE	TANK LOADS PER ACRE									
		30LBS/100		35LBS/100		40LBS/100 *		45LBS/100		50LBS/100	
200	1000	60 lbs/tank	16.67	70 lbs/tank	14.29	80 lbs/tank	12.50	90 lbs/tank	11.11	100 lbs/tank	10.00
	1200		20.00		17.14		15.00		13.33		12.00
	1500		25.00		21.43		18.75		16.67		15.00
	1700		28.33		24.29		21.25		18.89		17.00
	2000		33.33		28.57		25.00		22.22		20.00
	3000		50.00		42.86		37.50		33.33		30.00
500	1000	150 lbs/tank	6.67	175 lbs/tank	5.71	200 lbs/tank	5.00	225 lbs/tank	4.44	250 lbs/tank	4.00
	1200		8.00		6.86		6.00		5.33		4.80
	1500		10.00		8.57		7.50		6.67		6.00
	1700		11.33		9.71		8.50		7.56		6.80
	2000		13.33		11.43		10.00		8.89		8.00
	3000		20.00		17.14		15.00		13.33		12.00
1000	1000	300 lbs/tank	3.00	350 lbs/tank	2.86	400 lbs/tank	2.50	450 lbs/tank	2.22	500 lbs/tank	2.00
	1200		3.60		3.43		3.00		2.67		2.40
	1500		4.50		4.29		3.75		3.33		3.00
	1700		5.10		4.86		4.25		3.78		3.40
	2000		6.00		5.71		5.00		4.44		4.00
	3000		9.00		8.57		7.50		6.67		6.00
1300	1000	390 lbs/tank	2.31	455 lbs/tank	2.20	520 lbs/tank	1.92	585 lbs/tank	1.71	650 lbs/tank	1.54
	1200		2.77		2.64		2.31		2.05		1.85
	1500		3.46		3.30		2.88		2.56		2.31
	1700		3.92		3.74		3.27		2.91		2.62
	2000		4.62		4.40		3.85		3.42		3.08
	3000		6.92		6.59		5.77		5.13		4.62
1500	1000	450 lbs/tank	2.00	525 lbs/tank	1.90	600 lbs/tank	1.54	675 lbs/tank	1.48	750 lbs/tank	1.33
	1200		2.40		2.29		1.85		1.78		1.60
	1500		3.00		2.86		2.31		2.22		2.00
	1700		3.40		3.24		2.62		2.52		2.27
	2000		4.00		3.81		3.08		2.96		2.67
	3000		6.00		5.71		4.62		4.44		4.00
2000	1000	600 lbs/tan	1.50	700 lbs/tank	1.43	800 lbs/tank	1.25	900 lbs/tank	1.11	1000 lbs/tank	1.00
	1200		1.80		1.71		1.50		1.33		1.20
	1500		2.25		2.14		1.88		1.67		1.50
	1700		2.55		2.43		2.13		1.89		1.70
	2000		3.00		2.86		2.50		2.22		2.00
	3000		4.50		4.29		3.75		3.33		3.00
3000	1000	900 lbs/tank	1.00	1050 lbs/tank	0.95	1200 lbs/tank	0.83	1350 lbs/tank	0.74	1500 lbs/tank	0.67
	1200		1.20		1.14		1.00		0.89		0.80
	1500		1.50		1.43		1.25		1.11		1.00
	1700		1.70		1.62		1.42		1.26		1.13
	2000		2.00		1.90		1.67		1.48		1.33
	3000		3.00		2.86		2.50		2.22		2.00

HAY/STRAW TACKING

Hay or straw mulches can be economical by comparison to hydraulically applied mulches. Application rates for hay and straw mulches are usual at 3000-4000 lbs. per acre.

Reinco Power Mulchers (models rated from 2 to more than 20 tons per hour) can be utilized to broadcast these mulches quickly, thereby reducing the labor-hours on the site, and minimizing the water requirements dramatically.

Newly applied hay or straw mulches are subject to displacement by the forces of wind and rain, unless properly anchored. Tacking is an effective method of 'insurance', minimizing this displacement potential.



The **HG-13GX HYDROGRASSER** may be used to apply binders or tackifiers to hay or straw mulches already placed. The most common tackifier slurries use specially formulated powders that are known as hydrophilic colloids. They are quickly hydrated by the agitation produced by the **mixing jets**.

The resultant viscous slurry is then applied as an over spray to the previously applied hay or straw mulch. Typical tackifier slurry contains 50-100 pounds of paper or wood fiber mulch per acre. The addition of the processed fiber provides two benefits. First, the green dye used to color the mulch, serves as a spotting agent, to assist the operator in gauging placement. Second, the discrete fibers of the fiber mulch serve to link the slurry droplets together as they are sprayed over the long fiber mulch mat.

Using **Reinco TRACER™ Tackifier** as a mulch binder, the following mix is suggested per tank load for flat areas:

Amendments Per Batch

WATER=800-1000 gal.
Reinco TRACER™ Tackifier = 10 lbs.
FIBER = 50-100 lbs.

The 1300-gallon working volume would then be capable of a full two-acre application. Broadcasting at a low pressure with large droplets assures that the 'splat' will bond the long fiber strands, as well as reducing the amount of material required.

TACKIFIERS

Originally, emulsified asphalt was used predominantly for holding hay or straw mulch in place. Although contractors still use this oil based tackifier, its use is becoming less common due to high cost, environmental concerns, availability problems and the associated cleanup liabilities in congested areas. An emulsion spray system option is available on some Power Mulcher models to spray the 'tar' tackifier into the discharged mulch as it is placed.

Alternative 'environmentally friendly' tackifiers are available in either liquid or powder form, yet both are always applied in a liquid slurry state through a HYDROGRASSER or a similar mixing/spraying apparatus.

Hydraulic mulch can be used as a tackifier sprayed onto hay or straw at the recommended rate of 700-850 pounds per acre. Hydraulic mulch applications are water intensive. Tackifiers mixed with hydraulic mulch dramatically reduce material requirements and increase the effectiveness of the application.

TRACER™ TACKIFIER

Reinco TRACER™ Tackifier is a powdered, multipurpose, hay and straw tackifier, fiber mulch binder, and temporary soil stabilizer, designed for mixing in a Hydrograsser, Tackifier applicator, or with similar equipment, for use by professional landscape contractors.

The formulation includes a *Tracing* agent, or dye, useful by both contractors and inspectors, in metering application over long fiber mulches.

This product is the latest in our tackifier line that spans several decades. It replaces our prior formulations that include: **Terra Tack™**, **Terra Tack™ AR**, **Terra Tack™ MP**, and **RMBplus**.



Reinco TRACER™ Tackifier is packaged in 5-pound (2.27 kg) jars, packed 6 per case and 36 cases per pallet. It is available through Reinco's network of equipment dealers and landscape supply houses or direct from Reinco, and may be shipped via UPS.

PRODUCT USES

- Hydraulic Seeding
- Erosion Control
- Storm Water Run-off
- Slope Stabilization
- Dust Control
- Silt Control
- Construction and Development
- Roadway vegetation installation
- Alternate Daily Cover (ADC) in Landfills
- Non traffic path and road surfaces
- Agricultural soil displacement protection
- Forestry and Logging site remediation

APPLICATION

- Mix and apply Reinco TRACER™ Tackifier with a Hydrograsser, Tackifier applicator, or with similar equipment.
- Reinco TRACER™ Tackifier may be used alone or in combination with other materials and methods.
- Reinco TRACER™ Tackifier may be applied to the soil surface prior to mulch application for increased soil stabilization.
- End user may, at own risk, modify the recommended application rates based upon design specification and experience.

MIXING INSTRUCTIONS

- For best results, with tank $\frac{1}{4}$ - $\frac{1}{3}$ full and while agitating, slowly add Reinco TRACER™ Tackifier to a point of greatest agitation to promote even distribution within the water.
- Add any additional ingredients required while completing the tank fill.
- Maintain mixing throughout transportation and application.
- Clean by flushing tank, lines and hose with clear water.

Tracer is compatible with other materials commonly used in hydraulic plantings.

APPLICATION RATES

- **Erosion Control, Hydraulic Seeding**
Mix and apply Reinco TRACER™ Tackifier at a rate of **5 pounds per acre**. Add 1 lb. of Tracer for each 300 lbs of fiber mulch. The application of Reinco TRACER™ Tackifier will enhance the performance of hydraulic mulches.
- **Hay and Straw Tacking**
Mix and apply Reinco TRACER™ Tackifier at a rate of **5 pounds per acre**. Mix Reinco TRACER™ Tackifier at a rate of 5 pounds with 500 gallons of water and 40-50 pounds of processed fiber mulch material. Broadcast at low pressure to assure large droplet dispersion.
- **Storm Water Run-off**
Reinco TRACER™ Tackifier may be applied at a rate of 5 pounds per acre to aid in the prevention of sheet erosion and to control sediment runoff.
- **Alternate Daily Cover (ADC)**
Add 1 pound of Tracer to each 5000 sq ft. application of ADC mixture.
- **Furrow erosion induced by irrigation**
Apply 2 pounds of Tracer to the head of each one-acre furrow.

PRODUCT NOTES & CAUTIONS

- DO NOT apply directly to any body of water or allow run-off to enter any body of water or drainage system.
- NOT FOR USE with pesticides.
- NOT INTENDED for use as a potable water clarifier.
- The use of certain fertilizers may enhance the effectiveness of this product.
- Colorant will stain paint or newly concreted surfaces. Staining can be minimized by washing thoroughly with clear water.
- Dye intensity will reduce with exposure to light.

SAFETY CAUTIONS



CAUTION!

KEEP OUT OF REACH OF CHILDREN

AVOID prolonged contact with skin

Do not breathe dust or ingest.

KEEP OUT of eyes. If in eyes flush with clean water for 15 minutes and repeat as necessary.

If spilled rinse with water until clean. Clothing may be washed in normal fashion.

Spilled product may result in a SLIP HAZARD - clean up spills immediately; if wet spill, an absorbent such as vermiculite may be used to aid in clean up. Spilled materials may be recovered and used in the normal manner.

DO NOT apply to newly painted or paved surfaces - may cause slippery conditions when used in vehicular traffic areas.

MORE INFORMATION

Reinco TRACER™ Tackifier specifications and **MSDS** is available either

- on line at <http://www.reinco.com/>
- by Fax or Mail call Reinco

CHARGING SEQUENCE

Pouring amendments into the mix is not arbitrary. Experience and preference will dictate the sequence. Normally charging may start with about a third of a tank of water to utilize the remaining fill time. The procedure outlined under 'Trial Run' on pg. 18, should be routinely followed prior to starting the charging sequence. Before starting the unit, make sure all system valves are in the 'off' position. Once started, inspect the operation of the hydro-jets as well as the grinder assembly. Routinely inspect the spray boom discharge and hose(s) before committing to a complete charge.



WARNING! DO NOT ATTEMPT TO LOAD OR CHARGE THE UNIT WHILE IN TRANSIT. LOAD ONLY WHEN PARKED ON LEVEL GROUND.

CHARGING WATER

The machine fill assembly provides easy control of fill water from select sources. Connect a fill pump or hydrant hose to the fill pipe connection. Once the fill water source has been actuated, turn both ball valves on. When the tank is approximately 1/3 full, shut off the tank top valve to start the machine and complete the system inspection. If everything appears to be in order, resume the fill while charging the slurry materials. When the fill is complete turn off the tank top valve; connect a garden hose to the bib to clean up spilled materials.

LOADING GRANULAR MATERIALS

Bagged granular materials are quickly loaded by slashing the middle of the bag on the bag breaker bar in the forward hatch and lifting on the ends to pour these materials directly into the hatch. Care must be taken to insure that only the contents fall into the tank. Empty bags, as well as scraps and pieces may cause serious plugs.

LOADING FIBER MULCH

Fiber mulch is usually packaged in heat sealed bales or plastic lined paper bags. Support the bale on the grinder hatch lid, cut the packaging from the bale with a razor or knife, around the middle, and then slide the packaging off and away from the bale. Take care not to drop the packaging into the slurry. Break the bale section into the hatch opening allowing the mulch to drop onto the rotating grinder. The engine may be 'revved up' as the slurry thickens, to maintain adequate agitation. Use care to insure that sufficient water is charged as each bale of fiber is introduced. Turn off the grinder/blender momentarily to observe and assure that the baled material is separating and dispersed in the agitating slurry. Turn the grinder/blender on until the materials are fully wetted. Close the grinder/blender supply valve and allow a few minutes mixing to incorporate any floating materials.

MIXING TACKIFIER

When **Reinco TRACER™ Tackifier** is used, it must be added before the fiber is loaded, allowing the material to fully hydrate and disperse in the water. Slowly pour the tackifier into the tank directly through the loading hatch taking care not to allow clumps to form.



NOTICE! Binder (tackifier) products, when hydrated, are extremely slippery before curing. Wash down and wipe surfaces where product has been unintentionally sprayed or applied. This is especially important while working on or around the machinery.

LOADING SEED

Seed is often added to the slurry near the end of the charging cycle through either hatch. Run the grinder/blender for a few minutes to draw the seed off the surface and into the slurry.

OTHER AMENDMENTS

When mixing additional ingredients into the batch, consult the materials manufacturers for recommendations. The **HG-10GX3 HYDROGRASSER** can be utilized to mix and distribute a variety of other materials for alternate applications due to its functionally simple design. Be sure to follow the manufacturer's recommendations for mixing, broadcasting, and cleanup.

ONCE CHARGING IS COMPLETE, turn off the grinder/blender momentarily to check the uniformity of the slurry. Turn the grinder/blender on until mixing is complete. When the mixture appears evenly distributed, you are ready to proceed. Seldom is more than five minutes mixing time required for adequate batching. Different types of material will require adjustment in mixing time and procedures. Often, complete mixing occurs during the transport time from the fill (charging) site to the placement area.

TACKIFIER

TACKIFIER IN THE HYDROGRASSING MIX

Tackifier as an ingredient in the hydrograssing slurry is often termed a binder. The binder (glue) adheres to the fibers providing the applicator with the ability to create a permeable mat like fabric for air circulation and light passage, while controlling the evaporation of moisture from the seedbed. Adding the tackifier to the mix insures the placement of the materials. This additive offers protection against the reworking of areas due to unforeseen wind and rain events. Additionally, the water (moisture) retention ability of the applied materials dramatically offsets irrigation requirements. Some hydraulic mulch products incorporate tackifiers in the blended product packaging, however control of the application rates are minimal. These products are ideal for situations where specifications are not exacting, and where the site can be monitored for unforeseen complexities.

As with mulch rates, depending on site conditions, more or less tackifier material may be required for particular scenarios. Sloped sites are subject to wind and water run off, unprotected flats may have a significant exposure situation, and combination sites having multiple application conditions; all having considerably different requirements. Using a quality multipurpose product assures that specifications can be met for whatever the specific conditions require. Quality tackifiers can reduce irrigation dependencies under certain circumstances.

TACKING HAY OR STRAW MULCH

When used to secure hay or straw mulch, a tackifier is defined as glue applied as an over-spray onto the mulch serving as a bonding medium. The individual strands are stuck or 'tacked' together to form a continuous mat. Tackifier application rates vary with the product but sufficient quantities should be used to prevent the mat from lifting from the prepared soil surface.

The preferred method for applying tackifier slurry is to broadcast the slurry upward at low pressure forming large droplets. The large droplets 'splat' onto the long fiber strands then weep through and adhere to the underlying prepared seedbed, locking the mat in place as the tackifier mixture cures.

Broadcasting the slurry mixture at a high pressure will cause the tackifier to set on top of the previously applied mulch material, and would require substantially more material to form an effective 'paperweight'.

Originally, emulsified asphalt was used as the preferred material for holding hay or straw mulch in place. The 'tar' would remain plastic enough to weep into the mat, linking the strands before curing. Although contractors still use this oil based tackifier, its use has become less common due to high cost, environmental concerns, availability problems and the associated cleanup liabilities in congested areas.

The emulsion spray system option offered on some Power Mulcher models are utilized to spray the emulsified asphalt tackifier into the discharged mulch as it is placed. Cleanup and maintenance of the application equipment is costly and labor intensive.

The alternative 'environmentally friendly' tackifiers are available in either liquid or powder form, yet both are always applied in a liquid slurry state through a Hydrograsser, Tackifier Applicator or a similar mixing/spraying apparatus.

Hydraulic mulch alone can be applied as a tackifier sprayed onto hay or straw at the recommended rate of 700-850 pounds per acre. These applications are water intensive as noted in the one step seeding process; sufficient water is required to slurry and broadcast the material. As hydraulic mulch alone, will dry out in the ambient climate, it becomes less effective as the water weight diminishes. Without tackifier the dry fibers do not have sufficient tenacity to secure the mulch from wind or rain events.

Tackifiers used with hydraulic mulch dramatically reduce material requirements and increase the effectiveness of the application. As little as one 40-50 lb. bag of mulch can be applied for a one acre application. The fiber mulch dye serves as a tracing agent for the operator to gauge the application, and the short fibers enhance the droplet adhesion of the tackifier product.

TACKIFIER AS A SOIL STABILIZER

Quality tackifier may be used for temporary dust control, to prevent wind and water caused erosion of stockpiles, temporary sealing for construction roads, landfills piles and roadways, and exposed pathways and recreation areas. Depending on the type of material chosen, application volume is dependent upon the term of protection expected. Some materials applied in diluted volumes have very little tenacity for soil adhesion, and degrade quickly in sunlight. The mixed material should be sprayed sufficiently to wet the soil surface to a specified depth, without causing puddling or running. Different soil types and climatic conditions will require an adjustment in the spray patterns, methods and material quantities.

Liquid tackifiers (Latex-Acrylics and Polymer Emulsions, etc.) are popular due to the easy dispersion in water, and ease of cleanup. Little if any agitation is needed; however, care must be given to flush and protect the equipment from residues. Depending upon dilution ratios, these tackifiers may offer superior holding power. Available in jugs, pails, drums and totes, these materials are not easily handled. Tackifier to water volumes make loading difficult. Color is usually milky white, and sometimes requires the inclusion of dyes for placement visibility.

Powdered products require some agitation to hydrate, are less bulky and are easily shipped and handled.

When cured, a water insoluble film is produced. Permeability is provided by the inherent bridging of soil particles.

REBATCHING

After every load there are residuals left in the tank. These residual materials should be freely moving in the remaining liquid. When the tank surges, the unit should be shut down with sufficient water to keep the remaining residuals moving freely. This is particularly true when using fiber mulches. Without sufficient water the materials cannot be pumped out. The effects of this build up include poor agitation, slow mixing, or plugging after consecutive rebatching.

The simplest way to avoid residual problems is to cut back on the amount of material to be added by estimating the quantity of material left in the tank after the prior load. Some compensation must be made during subsequent recharges due to this residual build up. With fiber mulch, the residual often is limited to 10-20 lbs of wetted material per batch.

During the recharge cycle, when the water level is approximately 1/3 full, start the engine and inspect the operation of the agitation streams. Also, open the control valve to actuate the blender. The residuals from the preceding load should be disbursed and practically unnoticed in the rolling water. If all does not appear to be in proper working order, stop filling and try to establish why. The small amount of effort expended at this point will save the inconvenience of working out a solution with a full load. Excessive fiber mulch residuals may indicate a wetting problem. If the mulch does not absorb sufficient water to slurry, check the hardness (mineral content) of the source water. Addition of a surfactant or "wetting agent", or acidifier will allow the mulch to absorb water faster and create a uniform slurry. If a continual residue buildup occurs, it is simply due to overloading. The logical correction is to adjust the fiber mulch to water ratio, thus producing a more pumpable mixture. It is worthwhile repeating:

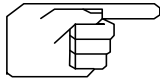

MAKE YOUR INSPECTIONS BEFORE COMMITTING TO A COMPLETE TANK FILL!

SPRAYING

Experience and practice will serve to develop a good spraying technique. By following a few simple guidelines, proper coverage can be assured. A novice operator may be trained by mixing a 1/4-acre batch of slurry in the **HYDROGRASSER**. Measure and stake out the area to be covered. Starting with the most remote point, spray out 1/2 of the batch in a crisscross manner. Check the tank slurry level frequently to insure that the operator is not distributing too much or too little. Overspray the remaining portion of the batch in the crisscross method covering the previous application. When the area has received full coverage, take note of the color and wetness of the sprayed area. This will serve as a gauge to the operator's eye for future applications.

1. The area to be covered will depend primarily upon the tank contents and job specifications. (Reference the section on MIX PREPARATION).
2. **Stake out or mark the determined area.**
3. Spray the described area in a crisscross manner, first from left to right, then top to bottom. Work the slurry placement from the most distant to closest, using only half a tank load.
4. Then retrace the first application placement with the remainder. For heavy applications it is best to overspray each application to dissipate the water used.
5. The most remote point should be covered first. Fully open the spray valve. If the engine must be revved up to reach the point, do so! Conversely, cut back the engine throttle to reduce the spray range when working close to the machine..
6. Control the spray range by adjusting the engine RPM. Throttling the spray valve will cause premature wear on the valve seals and will require repair or replacement of the valve.
7. When the slurry level drops to the point of surging, slow down the engine to get maximum pump-out.
8. Complete pump-out serves little purpose. When the pump loses prime, slow the engine down for a while to allow cooling and then shut off. Leave enough liquid in the tank to maintain movement of the residual materials.

REMOTE SPRAYING

On the flat, up to 300 feet of hose may be attached directly. Additional hose may be employed depending on the contour of the site, and the crew's ability to handle the additional lengths. A hose end spray valve is used to control the flow at the nozzle end.. (Although, contrary to recommended valve use, practicality dictates that periodic replacement of the valve outweighs the expense of another man stationed to control the engine speed.)

Remote spraying has limitations. When spraying, be mindful that the fluid volume and pressure is controlled by the engine RPM. As additional hose lengths are added the frictional pressure drop increases. This means lower pressure at the nozzle and a lesser spray range. If the hose is extended upward, over a rocky outcrop, for example, the additional vertical lift will reduce nozzle pressure, thereby cutting back on effective range. A compromise has to be achieved between flow and pressure to satisfy the requirements allowing this attachment to be fully effective.

On tank pump out be sure to close the remote spray valve (at the hose end) while it still contains slurry. This keeps the slurry in a fluid and pumpable state. Then shut off the supply valve at the machine. Recoil the hose without draining. Although heavy, this insures that the contained slurry will stay wet and pumpable. If preferred, the tank may be partially filled with water then pumped through to clean the hose. The remote spray valve can then be left open to drain the hose.

HOSE REEL OPTION

An option for remote spray flexibility is an electric rewind hose reel package. This option can be operated from ground level, with the additional advantage of providing power to assist in retracting the hose, and a drum providing fixed storage. Standard packages include 100 or 200 ft. of 1-1/4 or 1-1/2" black abrasion resistant hose, coupled male by female full flow (internally swaged) for easy connect and disconnect. A quick-coupled remote spray valve assembly is installed at the hose end for operator control of the spray application (ref: *Remote Spraying*). Up to 300 feet of 1-1/4" two braid water hose can be contained on the reel.

Other optional packages are available to suit almost any situation.

Collapsible (fire) hose is not recommended for use on reels because it restricts flow when coiled.

SPRAY BAR OPTIONS

Spray bar options are not intended for slurry use, but for dispersion of liquids for dust control, watering/feeding, deicing and washing applications, making the unit available for multi-seasonal use. The individual nozzles provide a fan pattern spray (50⁰ spray angle). By adjusting the nozzle angles alternate spray flows can be achieved. The rear spray assemblies incorporate individual nozzle shut-off valves as well as quick connect nozzle couplings. The forward assembly normally utilizes fixed nozzles with the support brackets providing the spray angle adjustments. Each arrangement provides an infinite variety of spray adjustments.

The rear spray bar mounts to the machine frame or chassis with standard 'U-bolts and is connected by hose to the spray boom discharge line.. A forward spray bar may be easily mounted to the vehicle bumper with adjustable brackets and clamping bolts and is connected by hose to the hydrograsser circulating manifold cleanout.

Each spray bar is actuated with a manually operated supply valve, and incorporates a strainer assembly to prevent residual Hydrograssing materials from discharge during the spray bar cycle.

As with routine **HYDROGRASSER** operation, fluid volume and pressure is controlled by the engine RPM. Spray bar applications commonly require pressure ranges approximately 10 to 20 psi, but may be adjusted much higher if required.

A trial run of clear water is recommended before operating the unit with solution. Fill the tank with approximately three hundred gallons of water. Start the unit and adjust the engine RPM to slightly above idle, then open the supply valve to the spray bar. Adjust the engine RPM to vary the intensity and volume of the spray pattern. The individual nozzles (spray patterns) may be adjusted at this time. With the setup complete the spray bar can be turned off and the spray solution charged.

When changing from Hydrograssing slurry applications to spray bar operation, care must be taken to flush and clean the tank of Hydrograssing residuals before charging the tank with spray bar solutions.

When the unit is returned to Hydrograssing service, be sure to close the supply valve and disconnect the supply hose to assure that contamination from granulars and fibers do not enter the spray bar system. Routinely clean the strainer element. Flow restriction from buildup can cause damage to the strainer assembly.

Solenoid actuated spray bars offer remote control capability and therefore minimize crew requirements. A 'cab operated' remote switch, mounted on the vehicle dash, providing on-off control of the spray system, actuates the solenoid valve. The in-line strainer prevents residual granulars and fibers from damaging the solenoid valve, which controls the system flow.

**REINCO MODEL HG-13GX
HYDROGRASSER**

MAINTENANCE AND SERVICE

MAINTENANCE

Due to the simplified construction of REINCO HYDROGRASSERS AND HYDROGRASSERS, most routine maintenance can be performed without the services of a skilled mechanic. In the event the unit requires expertise beyond that which is covered in this manual, contact your authorized REINCO servicing dealer.

If your REINCO dealer is not an authorized engine dealer, and the problem is engine related, contact an authorized engine service center. Call REINCO or your dealer for the name of your nearest engine service location.

The REINCO limited warranty, which follows, does not cover third party warranted components. The engine manufacturer provides their own limited warranty found in the engine section of this manual.

ABOUT WARRANTY

The equipment warranty statement is provided as protection to our valued customers, when or if the situation occurs, that a part or parts fail prematurely during normal use and service. The warranty period as provided allows the purchaser to make claim for repair or replacement of the parts deemed defective within that period. The procedure that follows will provide that claims made, may be expedited promptly and that settlement will be made fairly and amicably.

WARRANTY PROCEDURE AND FILING

1. **NOTIFICATION** - Promptly notify your dealer or REINCO of defect or failure and confirm in writing.
2. **AUTHORIZATION** - Upon receipt of authorization from REINCO, initiate replacement or repair under the terms and conditions of the warranty.
3. **RETURN GOODS** - Should part(s) be requested returned for inspection, obtain authorization for return (RGA). Return part(s) to REINCO Inc., freight prepaid. A copy of the return authorization should accompany the shipment.
4. **SUBMIT** - Claims submitted for warranty consideration will require copies of the notification, replacement part(s), invoice(s), and time record (Work Order). Copies of any additional correspondence with regard to the particular claim should be submitted as well.

Reinco's obligation under the terms of the warranty shall be limited to replacement or credit for the part(s). On request parts must be returned for inspection. Related labor must be considered fair and reasonable regarding work performed. A work order time record will be required to substantiate and validate labor reimbursement requests.

Claims submitted which upon review are determined to be the responsibility of third parties will be returned with instruction for forwarding to those parties.

Claims submitted for warranty consideration must be forwarded to REINCO for review within 30 days of the date of claim or the claim will be considered invalid and void. Settlement of any claim will require that any prior claims or adjustments be settled.

WARRANTY

The following warranty statement is provided to illustrate Reinco's typical Warranty. To the extent that there may be inconsistencies between this statement and that provided by the order Terms and Conditions, the order Terms and Conditions shall apply.

REINCO INC. provides a limited one-year warranty on the machinery of its own manufacture. REINCO INC. warrants to any buyer that the machinery shall be free of defects in material or workmanship during normal use and service for a period of one year from the date of shipment to the consumer. This warranty is not extended for machines placed into rental service.

Under this limited warranty, REINCO INC. shall within one week from the date of notification, (1) initiate replacement or action for repair of the part(s) proven defective in material OR workmanship or, (2) direct the servicing dealer to investigate, report, and then authorize and perform repair or, (3) on direct factory shipment, instruct the user, upon verification of failure, to perform his own repair with prior agreed upon back charges to REINCO INC. The choice of alternatives shall remain the sole decision of REINCO INC.

THIS WRITTEN WARRANTY IS THE ONLY WARRANTY MADE BY REINCO INC. IMPLIED WARRANTIES OF MERCHANTABILITY OR FITNESS FOR A PARTICULAR PURPOSE, IF ANY, ARE LIMITED TO THE SAME TERM AS THIS WRITTEN WARRANTY. CERTAIN STATES DO NOT ALLOW LIMITATIONS ON HOW LONG IMPLIED WARRANTY LASTS, SO THE ABOVE LIMITATIONS MAY NOT APPLY. HOWEVER, SOLELY WITH RESPECT TO THE BUYER, THE FOREGOING WARRANTY IS IN LIEU OF ANY AND ALL IMPLIED WARRANTIES INCLUDING, WITHOUT LIMITATION, IMPLIED WARRANTIES OF MERCHANTABILITY AND FITNESS FOR ANY PARTICULAR PURPOSE AND IN LIEU OF ALL OTHER WARRANTIES EXPRESSED OR IMPLIED, AND NO OTHER WARRANTY IS MADE OR AUTHORIZED TO BE MADE.

The user or dealer must promptly, within the limited warranty period, notify REINCO INC., and confirm in writing, the defects, allowing the Company to analyze the failure and determine its obligation under the warranty. Costs incurred by the user or dealer are to be absorbed, until settlement under terms of this warranty. The Company reserves the option and the right to have all defective components returned, transportation prepaid, for inspection.

This limited warranty does not cover unsatisfactory performance or failure due to misuse or abuse of the product, nor will REINCO INC. be responsible for unsatisfactory performance or failure DUE TO improper adjustment or repair of the product. The specifications are descriptive and are not warranties.

This limited warranty does not cover equipment and accessories manufactured by third parties.

REINCO INC. SHALL NOT BE RESPONSIBLE FOR CONSEQUENTIAL, SPECIAL, CONTINGENT, INCIDENTAL OR ANY OTHER DAMAGES WHATSOEVER IN CONNECTION WITH REPLACEMENT, REPAIR OR REFUND AS SET FORTH ABOVE. CERTAIN STATES DO NOT ALLOW THE EXCLUSION OR LIMITATION OF INCIDENTAL OR CONSEQUENTIAL DAMAGES, SO THE ABOVE LIMITATION OR EXCLUSION MAY NOT APPLY. THIS WARRANTY GIVES YOU SPECIFIC LEGAL RIGHTS AND YOU MAY ALSO HAVE OTHER RIGHTS IN ACCORDANCE WITH YOUR STATE LAW.

MAINTENANCE SCHEDULE

After each load, be sure to wash down any residual materials spilled or over-sprayed onto the machine. This is easiest accomplished during the water fill between loads or when rinsing residuals from the tank.

- FIRST 4 HOURS** TORQUE ENGINE AND PUMP MOUNTING BOLTS.
RECHECK PUMP/ENGINE COUPLING ALIGNMENT.
RETORQUE COUPLING SET SCREWS.
INSPECT PUMP SEAL/ LUBRICATOR.
CHECK ENGINE CONTROLS.
CHECK ENGINE FLUID LEVELS.
- EVERY 4 HOURS** INSPECT PUMP SEAL/ LUBRICATOR
ADD GREASE AS REQUIRED.
- EVERY 20 HOURS** OIL THE ENGINE THROTTLE MECHANISMS.
LUBRICATE SPRAY BOOM SWIVEL JOINT.
LUBRICATE HOSE REEL SWIVEL JOINT.
INSPECT AND CLEAN ENGINE AIR CLEANER.
REPEAT THE FIRST 4 HOURS INSPECTION.
- EVERY 40 HOURS** CHECK ENGINE OIL AND BATTERY ELECTROLYTES.
CLEAN CHAFF AND DEBRIS FROM ENGINE COOLING
FINS.
- EVERY 80 HOURS:** TUNE UP ENGINE, CHANGE OIL AND FILTER.
REPLACE AIR CLEANER CARTRIDGE.
CHECK PUMP IMPELLER CLEARANCE.
GREASE PUMP POWER FRAME BEARINGS.
GREASE GRINDER SHAFT BEARINGS.
INSPECT HOSES AND FITTINGS FOR LEAKAGE OR
WEAR.

DO NOT OVER-GREASE BEARINGS!
A SHOT OR TWO OF GREASE AT 80-100 HR. INTERVALS IS ADEQUATE!

For specific **ENGINE** maintenance instructions,
please refer to the engine manufacturer's manual.

Please refer to the specific **OPTIONS** descriptions and
corresponding parts pages for maintenance and service information.

MAINTENANCE OVERVIEW

The life of your equipment investment relates directly to the care you give it. By following the recommendations below, your new Hydrograsser should last many years.

BASIC

- GENERAL:** Keep your machine clean. Inspect pump, lubricator, drive coupling, engine, oil and air cleaner before and after each use. Remove all dirt and chaff from the engine with a brush. Pay particular attention to the engine air intake at the radiator chaff screen.
- SAFETY:** Perform a daily inspection of the machine from a safety viewpoint. Replace safety decals when worn, faded or damaged.
- HYDRO JETS:** Routinely inspect the streams produced by the Hydro-jets. If the jet is clogged, the circulating manifold must be removed and the jet cleared of obstruction. Replacement of the jets will be required when the orifice has been worn sufficiently to reduce system pressure. The cast nozzle orifice measures 5/8"high X 3/4"long oblong. Rounding of the oblong orifice is evidence of wear from granulars. With the manifold removed, the worn jet is knocked out of its retainer from inside of the tank. The replacement jet should be aligned so that the flat of the orifice is even with the tank bottom.
- PIPING:** The grooved end piping and couplings allow for quick assembly and disassembly of the system components when maintenance or service is required. The molded gaskets allow for easy alignment of the pipe clamps. When reinstalling the clamps, Coat the gaskets with a non-absorbing grease to prevent pinching or tearing of the gasket material. Threaded components must be assembled with a thread sealant compound to assure ease of disassembly for servicing. Routinely inspect piping and connections for wear and replace worn component completely.

DRIVE TRAIN

- BEARINGS:** The most common error committed by the casual operator is over lubrication of bearings. A shot or two of grease (Fiske Lubri-plate 930-AA or equivalent) every 100 hours is adequate. Periodically check locking collar set screws for tightness.
- The drive coupling transmits power to the blower and pump. Excessive misalignment of the shafts (axial or angular) will produce vibration. If so, realign coupling as necessary. Check the set screws and connecting bolts every 100 operating hours for loosening or other abnormality.
- If the coupling becomes misaligned, contact your servicing dealer. Otherwise, follow this procedure: Determine the direction and degree of misalignment by measuring with a caliper or divider around the periphery of the drive coupling flanges. If the gap is measured on the top of the driven coupling flange, this indicates that the shaft[s] have shifted downwards. If a gap is measured in the side of the driven flange this indicates that either the pump assembly has shifted, or the driven shaft (engine) has shifted.
- If misalignment is detected, determine whether to adjust the pump or engine [shim as required]. Make the adjustment, then re-measure the two coupling flanges. If the gap is eliminated, tighten all bolts and again check alignment. If coupling is aligned, start engine and check for vibration. If vibration exists contact your servicing dealer or the factory for assistance.
- For more information on coupling alignment, see "DRIVE COUPLING ALIGNMENT" .
- DRIVE COUPLING:**
- ENGINE:** Daily inspection involves checking oil level, air cleaner and removing dirt and chaff from engine cowl. Refer to engine manual for the manufacturers maintenance schedule and further details.
- A governor setting limits the rpm nominally at 2600 under load. If the max RPM exceeds 2600, readjust this setting. Recheck the engine RPM setting any time engine service is performed (ie. replacement throttle control, engine tune up, etc.)
- PUMP:** The pump provides both agitation and discharge pressure. Should sytem pressure or spray range drop off suddenly, the pump impeller may be clogged. If the drop is over a period of time, the pump impeller is worn and requires adjustment or replacement.
- (Note: If the impeller is worn, the hydro-jets will be worn similarly).
- PUMP SEAL:** Should the mechanical seal fail, the first indication will be dripping slurry from the seal area of the pump. Replacement must be made immediately or the bearings will be ruined.

BLENDER ASSEMBLY

GENERAL:

Daily inspection includes checking hoses and fittings for leakage. Do not operate the blender system with leaking hoses or fittings. Remedy by replacing the failing component completely. Inspect the grinder teeth and bolts for loosening or breaking. Replace the grinder teeth when worn.

HYDRO JET:

Periodically inspect the grinder drive hydro-jet nozzle for wear. Replace as required. Check the alignment of the stream driving the grinder/blender, adjust as required. Torque the bearing and aligning collar set screws.

If the grinder stops, the supply valve or line may be obstructed. Shut down the engine. Inspect and remove any obstructions.

DISCHARGE ASSEMBLY

RANGE:

Discharge range is controlled by engine speed. Check engine RPM. If not 2600, reset the throttle/governor control.

Wear from abrasives will reduce system-operating pressure. Check pump impeller clearance and adjust as required. Inspect hydro-jet nozzles for wear, replace as required.

ROTATION:

If the boom swivel becomes hard to turn, the seals and/or the ball races may be worn from slurry granulars. Clean and determine if replacement of the swivel joint packing is required.

TROUBLE SHOOTING

There are occasions when the operation of the HYDROGRASSER may not be at its peak. Wear is a factor that must be considered depending on usage. Many times, however, other conditions affect performance. The following are examples of outward indications of potential problems, which usually can be corrected, with a minimum of Effort

SYMPTOM	POSSIBLE CAUSE	POSSIBLE REMEDY	REF
NO SPRAY AND NO AGITATION	WATER LEVEL TO LOW	ADD WATER	STARTUP/ TRIAL RUN
	PIPING OBSTRUCTED	DETERMINE LOCATION AND CLEAR OBSTRUCTION ADD WATER TO RESIDUAL SLURRY BEFORE RESTARTING UNIT	REBATCHING
	OBSTRUCTION AT PUMP IMPELLER	CLEAR OBSTRUCTION	MAINTENANCE OVERVIEW
	PUMP FAILURE	DETERMINE CAUSE. REPAIR AS REQUIRED	PUMP MAINTENANCE
NO SPRAY, AGITATION NORMAL	DRIVE COUPLING FAILURE	DETERMINE CAUSE. REPAIR AS REQUIRED	COUPLING ALIGNMENT OR REPLACEMENT
	SPRAY BOOM PIPING OBSTRUCTED	DETERMINE LOCATION AND. CLEAR OBSTRUCTION	REBATCHING
LOW SYSTEM PRESSURE	HOSE OBSTRUCTED	DETERMINE LOCATION AND CLEAR OBSTRUCTION	REMOTE SPRAYING
	IMPELLER OUT OF ADJUSTMENT	ADJUST IMPELLER CLEARANCE	MAINTENANCE OVERVIEW
	IMPELLER WORN BEYOND ADJUSTMENT RANGE	REPLACE IMPELLER	PUMP MAINTENANCE
	HYDRO-JETS WORN	REPLACE HYDRO-JETS	HYDRO JET REPLACEMENT
GRINDER DOES NOT TURN OR STALLS	LOW ENGINE RPM	SERVICE ENGINE TO OBTAIN OPERATING PRESSURE UNDER LOAD	MAINTENANCE OVERVIEW
	SUPPLY LINE. OBSTRUCTED	DETERMINE LOCATION AND CLEAR OBSTRUCTION	GRINDER ASSEMBLY
	AIR ENTRAINED IN LIQUID	CHECK SLURRY LEVEL	AERATION
POOR AGITATION	WORN OR LEAKING SUPPLY VALVE	REPLACE SUPPLY VALVE	BALL VALVE SERVICING
	LOW SYSTEM PRESSURE	DETERMINE AND CORRECT CAUSE	LOW SYSTEM PRESSURE
	JETS OBSTRUCTED	REMOVE OBSTRUCTION	HYDRO JETS
	WORN JETS	REPLACE JETS	HYDRO JETS
DISCHARGE VALVES OPEN OR WORN	ENGINE RUNNING TO SLOW	DETERMINE AND CORRECT CAUSE	ENGINE
	CLOSE DISCHARGE VALVE AND/OR REPLACE IF WORN		BALL VALVE SERVICING

REINCO HG-13GX3 HYDROGRASSER •SAFETY•OPERATION•SERVICE•PARTS MANUAL

SHORT RANGE	LOW SYSTEM PRESSURE	DETERMINE AND CORRECT CAUSE	LOW SYSTEM PRESSURE
	GRINDER SUPPLY VALVE LEFT OPEN OR WORN	CLOSE GRINDER SUPPLY VALVE AND/OR REPLACE IF WORN	BALL VALVE SERVICING
	PLUG OR RESTRICTION IN SUCTION LINE	DETERMINE LOCATION OF PLUG. CLEAR OBSTRUCTION	REBATCHING
	IMPELLER OBSTRUCTED	REMOVE OBSTRUCTION	MAINTENANCE OVERVIEW
PLUGGING	UNIT LOADED ABOVE RATED CAPACITIES	LOAD UNIT PROPERLY PER RATINGS	MIX PREPARATION
	MATERIALS CONTAIN CONTAMINANTS	CONTACT MATERIALS SUPPLIER FOR ASSISTANCE	REBATCHING
	MULCH NOT WETTING	ADD WETTING AGENT	REBATCHING
		CONTACT MULCH SUPPLIER FOR ASSISTANCE	REBATCHING
	IMPROPER LOADING PROCEDURES	CHARGE MACHINE IN PROPER SEQUENCE	CHARGING SEQUENCE
LOW SYSTEM PRESSURE	DETERMINE AND CORRECT CAUSE	LOW SYSTEM PRESSURE	
PLUGGING ON RELOADS ONLY	IMPROPER ALLOWANCE FOR RESIDUALS LEFT IN TANK	RE-BATCH FOLLOWING CORRECT PROCEDURES, ALLOWING FOR MATERIAL STILL IN TANK	REBATCHING
ENGINE / PUMP VIBRATION	OBSTRUCTION CAUSING IMPELLER IMBALANCE	REMOVE OBSTRUCTION	MAINTENANCE OVERVIEW
	PUMP BEARING FAILURE	INSPECT BEARING ASSEMBLIES AND REPLACE IF REQUIRED	PUMP MAINTENANCE
	ENGINE RUNNING ROUGH	SERVICE ENGINE	MAINTENANCE OVERVIEW
	DRIVE COUPLING FAILURE	INSPECT COUPLING FOR WEAR OR MISALIGNMENT -SERVICE AS REQUIRED	COUPLING ALIGNMENT OR REPLACEMENT

SERVICING THE HYDROGRASSER

GRINDER/BLENDER ASSEMBLY

Daily inspection includes checking the system hoses and fittings for leaks. Do not operate the system with leaking hoses or fittings. Remedy by replacing the failing component completely.

The grinder supply valve must be operated either completely open or closed. Operating the grinder by partially opening the valve will quickly wear the seats and internal parts due to the granular materials being pumped. Replace the worn valve completely.

The blender is supported by two sealed pillow block bearings. Periodically inspect these bearings for wear. The blender assembly should not be operated when the slurry level is below the bottom blender blades. Bending of the shaft from whipping may occur. Excessive vibration from the bent shaft will quickly wear the shaft bearings. If replacement of the shaft or bearings is required, be sure to align the grinder wheel with the drive jet. Make sure the bearing-locking collar set screws and coupling setscrews are torqued when adjustments are made.

HYDRO-JET NOZZLES

The **HYDRO-JET** nozzles, or agitator jets, are located inserted into retainer nipples on the tank wall near the bottom of the tank. The grinder supply nozzles are retained similarly in the supply line assembly. The nozzles are tapered to provide the agitating pressure. These agitator nozzles will eventually wear and enlarge from slurry granulars. It is important to realize that if the **HYDRO-JET** nozzle requires replacement, the pump impeller typically will also require adjustment, and visa versa.

Replacement of the agitator nozzle requires that the worn nozzle is driven outward from the retaining nipple. The new nozzle is installed with the tapered end facing into the tank. When replacing the agitator nozzle adjust the spray to maintain a horizontal flow.

Fill unit partially with water, start and inspect for leaks and proper agitation.

DRIVE COUPLING SERVICE

When servicing the coupling, it is important that the centerline of the driven shaft be true to the centerline of the driver shaft. Wear on the flexible element due to the axial and radial misalignments will be avoided with proper alignment.

COUPLING SHOULD BE ALIGNED WITHIN .005" PARALLEL AND .092" ANGULAR.

1. To check PARALLEL drive coupling alignment, use a notched straight edge (notch should be sufficient to clear the center member) and a feeler gauge. Place the straight edge across the two coupling flanges and measure the maximum offset at various points around the periphery of the coupling without rotating the coupling. If the maximum offset exceeds .005", realign the shafts.
2. To check ANGULAR drive coupling alignment, a micrometer or caliper must be used. Measure from the outside of one flange to the outside of the other at intervals around the periphery of the coupling. Determine the maximum and minimum dimensions without rotating the coupling. The difference between the maximum and minimum must not exceed .092". If correction is required be sure to recheck the parallel alignment.
3. In the field, the angular measurements may be approximated with a tape or ruler. Use opposite reference positions on the driven shaft flange, measuring to respective locations on the perimeter of the coupling flange (engine side). The variations should be limited to 1/32". However, this method should be rechecked as soon as possible as indicated above.

COUPLING ALIGNMENT OR REPLACEMENT

It should not be necessary to replace any parts on the drive coupling assembly, provided that misalignment is discovered at the onset. The following procedure covers the method to replace an entire coupling assembly, and may also be used as a guide for alignment also.

1. Inspect the coupling assembly for damage. Secure replacements as required.
2. Remove any protective coatings or lubricants from bores, mating surfaces and fasteners. De-burr any marred surfaces and edges.
3. Slide one coupling flange onto each shaft. The keys must fit snugly. Should the fit be loose, find out why and correct before proceeding further. Nest the sleeve (flexible element) with metal ring within one flange. Draw the two flanges together with some clearance between the element and flanges (approx. 1/32" total or 1/64" per side). Center the flanges between the two shafts. Then, using a thread locking resin, torque the set screws on the flanges securely.
4. Check parallel and angular alignment as described above. Should the alignment be within specifications, proceed to step 6.
5. Loosen bearing and/or engine bolts, as required, to shim to correct the alignment. Torque the bearing and engine fasteners, then repeat step 4 to assure the alignment is maintained.
6. Recheck to insure that all fasteners and setscrews are securely torqued.

SWIVEL JOINT SERVICE INSTRUCTIONS

Repacking the swivel joint assembly is required when the joint seals have become worn from slurry granulars or fatigue causes excessive leaking. Remove the complete swivel joint assembly from the spray boom piping and follow the procedure outlined below:

1. Remove swivel joint service plugs and squirt solvent into each cavity to reduce grease.
2. Rotate the tailpiece to remove balls from races, collecting the balls on a rag, as they fall from the service port. A pair of long nosed pliers or pencil magnet may be required to remove any stubborn balls.
3. With the balls removed, the tailpieces will separate from the body section. Remove the worn seal from the body sections, and the 'O' rings from the tailpiece. Thoroughly clean all surfaces of grease, grit and dirt.
4. Coat all surfaces with light machine oil and install the new seals.
5. Replace the tailpieces into the body section with a slight twist to assure seating of the new seals.
6. Insert the balls through the service ports, swinging the tailpiece to completely load the races.
7. Replace the service plugs. If binding occurs, back off the plugs slightly.
8. Lubricate the assembly with #1 consistency waterproof grease. Rotate the tailpiece to insure adequate lubrication. **DO NOT FORCE GREASE.**

BALL VALVE SERVICING

ALL VALVES USED IN THIS APPLICATION ARE FULL FLOW BALL TYPE VALVES ALLOWING QUICK ON-OFF CONTROL OF THE SLURRY FLOW.

Partially opening or closing the valves will quickly cause the ball and or the valve seats to wear from the slurry granulars.

Replacement of the entire valve is recommended at this point. Repair or replacement of the worn parts is not often economical or effective.

HOUSEKEEPING

None of the ingredients used in the typical Hydrograssing mixes are particularly corrosive, but allowing them to cake and collect both inside and out of the machine will contribute to premature deterioration. Make it a practice to hose your unit down with clear water on a daily basis to prevent this. If a load or portion thereof is still in the tank, it can usually remain overnight or even two, without damage. One of the outstanding practical virtues of **HYDRO-JET** mixing is the ability to pick up dormant or settled loads relatively easily. However, with the tank empty, and having been given a good wash down, here is the procedure to follow to prepare the inside of the tank and associated piping for work the next day.

1. Fill the tank about 1/3 full. Start the engine; run at a moderate idle. Open the circulation supply valve for a burst or two, run some of the fill through the spray hose(s), discharging into the tank hatch to dilute residuals which may settle in the coiled
2. If the residual slurry is thin and moving freely, the machine can be shut down with the water remaining for the night. If the layover is going to extend for a longer period, the weekend, or 3 to 4 days, or during hot weather, the following additional steps should be taken:
3. Pump out the 1/3 tank load of weak slurry. Discharge the thinned slurry over the previously treated area to utilize the residual materials. Open the sump cap to drain the remaining residuals.
4. Close all valves and refill as described above. Actuate the control valves and again flush the lines with intermittent discharges. Then pump out the rinsate completely. To save time, remove the spray nozzle or hose valve assembly to get higher flows.
5. Turn off the engine, open the sump drain cap and manifold drain cap, then wash down and rinse the unit inside and out.

WINTERIZING AND STORAGE

When the season is over, properly storing the machine over the winter months will simplify spring start up.

1. **GENERAL:** Clean any residual materials on or around the machine. Thoroughly clean and rinse down unit both inside and out. Make sure the tank is fully drained.
2. **PAINTING:** Peeling or chipped paint, worn or rusty spots should be prepared, primed and repainted. The tank interior should be inspected and any worn paint areas recoated.
3. **ENGINE:** Perform the standard 80-100 hour check on the engine. Take care to clean any dirt or chaff from the engine cooling areas. The engine should be fogged to prevent sticking valves. Drain the fuel tank, then remove and store the battery. Refer to the engine manual for cold weather preparation.
4. **VALVES:** Open all valves. With cold weather conditions, the valves should be set in a 1/2 open position allowing water to drain from the sealing area.
5. **PUMP:** Drain the pump casing. Then add a biodegradable antifreeze or corn oil to prevent any residual water from freezing. This is most effective if added through the top casing plug while the engine is being fogged to well coat the interior pump components.
6. Check and adjust pump impeller clearance as required. Done now, the unit is ready for spring startup.
7. **PIPING:** Inspect and repair piping components as required, store drain caps and clamps in the storage compartment on the operator platform. Coat the gaskets with a non-absorbing grease when stored.
8. **COVER:** The unit should be stored inside during severe weather conditions. If indoor storage is not available then the entire unit should be tarped and secured under cover in a protected area.

REINCO HG-13GX3 HYDROGRASSER •SAFETY•OPERATION•SERVICE•PARTS MANUAL

**REINCO MODEL HG-13GX
HYDROGRASSER**

PUMP MAINTENACE GUSHER 7071 SERIES

MAINTENANCE INSTRUCTIONS FOR 7071 SERIES ANSI STANDARD DIMENSION CENTRIFUGAL PUMPS

As with any mechanical device, proper use and periodic maintenance will enhance the performance and life of your pump.

GUSHER PUMPS INC. SHALL NOT BE LIABLE FOR PHYSICAL INJURY, DAMAGE OR DELAYS CAUSED BY A FAILURE TO OBSERVE THE INSTRUCTIONS FOR OPERATION, AND MAINTENANCE CONTAINED IN THIS MANUAL.

WARRANTY

Gusher Pumps, Inc. will replace or repair, within one year of shipment from our plant, any pump in our judgment that has failed due to defects in materials or workmanship, provided the pump has been properly maintained and has not been subject to abuse. The pump must be returned to Gusher Pumps, Inc., with complete history of service, for inspection and warranty consideration. Gusher Pumps, Inc. does not accept responsibility for transportation to and from our plant. Furthermore, we do not assume any responsibility for consequential damage or loss of production.

On the casing of every pump is a nameplate that provides information about the pump's characteristics. This information will be required when ordering spare or replacement parts for your pump

When ordering service or spare parts the following information should be provided to enable accurate selection of part numbers for the specific pump in question:

Serial Number • Complete Model Number • Material of Construction

Discharge and Suction Size • Power Frame Size • Part Description

Safety precautions must be considered before any work is performed. Read and understand the warnings provided before disassembly of any component.

WARNING

Pump and piping components are heavy. Serious physical injury or damage to equipment could occur from failure to properly lift and support pump. Steel-toed shoes must be worn at all times. Use care when moving pumps. Lifting equipment must be able to sufficiently support the entire pump.

Drain all liquid from inside pump, certain materials may be slippery causing slipping and potential injury. Keep parts and the work area clean of contaminants and debris.

LUBRICATION



All pumps are lubricated at the factory before testing and installation. The bearing support frame will not require additional lubrication for approximately 1200 hours of operation.

SEAL LUBRICATION

The pump cartridge seal is fitted with an externally charged lubricator cup. The stem of the cup acts as an indicator to monitor consumption of the grease. The cup should be maintained full at all times. Check the stem periodically and recharge as the stem descends. Do not force grease into the cup, overcharging will deform the internal diaphragm and prevent the grease feed to the seal cavity.

OIL LUBRICATED FRAME

A high quality marine oil with rust and oxidation inhibitors, such as Mobil DTE 26 (300 SSU) or its equivalent, should be used. Fill bearing frame with oil until the level is at the center of the sight glass.

FRAME OIL CAPACITY

M Frame Approx 2 ¼ pints

GREASE LUBRICATED FRAME

When regreasing ensure that the grease container, greasing device, and the grease fittings are clean to prevent impurities from entering the bearing housing. Remove the 2 grease relief plugs from the bottom of the bearing frame. Fill grease cavities with Chevron SRI #2 or equivalent until fresh grease comes out of relief holes. Reinstall the grease relief plugs. Check the frame seals to ensure they are seated in the bearing housing. If not, press into place with drains located at the bottom. The bearing temperature will usually rise after regreasing due to an excess of grease. Temperatures should return to normal after the pump has purged the excess grease. Never mix greases of different consistency or thickener. If it is necessary to change the grease type, all of the old grease must be removed from the housing.

WARNING Lock out the engine power to prevent accidental startup and possible physical injury.

IMPELLER ADJUSTMENT



Over a period of time, a reduction in pump performance may be noticed. The granularS in the materials will wear on the internal components, increasing tolerances, and reducing overall system output capacities. Improved system performance can be accomplished by adjusting the impeller clearance.

1. Back off the drive coupling hub set screws on the pump shaft flange. The hub must be moved to compensate for any adjustment to the shaft/impeller arrangement.
2. Loosen the jacking screw lock nuts and back out the screws about two turns.
3. Turn in the bearing housing adjustment screws evenly until the front of the impeller bottoms on the impeller housing. Once contact has been made, back off the screws by a few flats of the hex head.
4. Tighten the jacking screws evenly by two flats (each flat of the hex screw provides approximately .007” adjustment), backing the impeller away from the housing. Tighten the locking screws and jam nuts evenly, being sure to maintain the proper clearance.
5. Check that the shaft is free turning, adjust the coupling hub as required, then reinstall the coupling set screws using a locking resin. Replace any guards removed

PUMP DISASSEMBLY

Over the life of the equipment occasional rebuilding of the pump may be necessary due to wear of the shaft, bearings or seal components. Disassembly of the complete pump is not difficult, having the proper tools available.

TOOLS REQUIRED

Spanner Wrench
 Shaft wrench
 7/16,9/16,3/4,7/8,15/16 Open End wrenches
 Torque Wrench and sockets
 Allen Wrenches
 Snap-ring pliers
 Brass Drift Punch

Lifting sling
 Feeler Gauges
 Dial Indicator
 Micrometer
 Induction Bearing Heater
 Cleaning Agents/ Penetrating Agents
 Hardwood Block



WARNING NEVER remove rotating assembly without assistance, physical injury may occur!

WARNING Pump and components are heavy. Serious physical injury or damage to equipment could occur from failure to properly lift and support pump. Steel-toed shoes must be worn at all times.



WARNING Operator must be aware of pump usage and safety precautions to prevent physical injury. Proper personal protective equipment should be worn.

WARNING Lock out engine power to prevent accidental startup and physical injury, 1. Drain piping and impeller housing, disassemble suction and discharge piping.
Remove coupling guard and set screws from the pump shaft coupling flange.



WARNING NEVER use heat to disassemble pump. Explosion could occur due to the expansion of trapped liquid. Use penetrating agents to assist in separating bound parts.

Drain the oil from the bearing frame and replace the drain plug, and then remove the oil sight gauge.

1. Remove the cap screws that secure the stem (18) to impeller housing (26).
2. Unbolt pedestal (14) from base, and Remove the rotating assembly (shaft, impeller, bearings) from housing (26) using a hoist
3. Remove stem plate gasket (24) and discard. Mark the location of the drive coupling hub on the pump shaft, then remove the hub.
4. To remove the impeller, place a wrench on shaft and rotate the impeller clockwise (viewed from impeller end of assembly) raising wrench off work surface. Quickly turn impeller opposite direction impacting wrench handle against solid block or work surface. Repeat process until the impeller loosens and can be turned from the shaft. Remove the impeller o-ring (17) from the end of the impeller and discard.
5. Unbolt the stem plate (23) from stem (18).
6. Unbolt seal/packing gland (19) from the stem plate.
7. Remove the stem plate.
8. Remove shaft sleeve (16) from shaft (9). The mechanical seal (21) will come off with sleeve.
9. Remove the seat and locking collar (22) from the sleeve.
10. Remove seal gland (19) from shaft.
11. Unbolt and remove stem (18) from bearing frame (13).
12. Remove adjusting screws, jam nuts, and locking screws from the bearing housing (6).
13. Remove the shaft and bearing housing assembly from bearing frame.
14. Remove the oil seal (15) from the bearing frame (13).
15. Unbolt and remove the thrust bearing retainer (2) from the bearing housing (6).
16. Remove the oil seal (3) from the thrust bearing retainer.
17. Remove the snap ring (4) from the shaft.
18. Slide the bearing housing (6) off of the thrust bearing (5).
19. Remove bearings (5 and 10) and bearing housing (6) from the shaft
20. Remove bearing housing o-ring (7) from bearing housing,
21. Remove bearing frame breather (12) and pedestal (14) from bearing frame (13).

REINCO HG-13GX3 HYDROGRASSER •SAFETY•OPERATION•SERVICE•PARTS MANUAL
COMPONENTS INSPECTION

Once the pump has been disassembled, thoroughly clean and inspect any parts that may be reused to ensure that they will fit and function properly. Any parts that do not meet the following standards should be replaced.

1. Inspect the impeller housing (26) for excessive wear or pilling. Inspect the stem plate gasket seat surface for irregularities.
2. Inspect the impeller (25) vanes for damage or wear. Replace impeller if vanes are worn in excess of adjustment. Inspect the edges of the vanes for pitting, erosion, or corrosion damage.
3. Inspect the stem (18) for cracks or excessive corrosion. Ensure the gasket surface is clean.
4. Inspect the shaft (9) and sleeve (16) for grooves or pitting. Ensure the shaft bearing fits are within tolerances.
5. Inspect the bearing frame (13) and pedestal (14) for cracks. Remove all loose foreign material from inside the frame. Ensure that all lubrication passages are clear.
6. Inspect stem plate (23) for pilling or wear.
7. Inspect the bearing housing (6) for cracks and pitting. Check that the bore is within tolerances. Inspect the bearings (5, 10) for contamination or damage. Do not under any circumstances reuse worn bearings.

Tolerances 7071M	
SHAFT O.D. INBOARD	1.7722" 1.7718"
	0.0010" tight 0.0001" tight
BEARING I.D. INBOARD	1.7717" 1.7712"
FRAME ID. INBOARD	3.9370" 3.9379"
	0.0015" loose 0.0000" loose
BEARING O.D. INBOARD	3.9370" 3.9364"
SHAFT O.D. OUTBOARD	1.7722" 1.7718"
	0.0010" tight 0.0001" tight
BEARING ID. OUTBOARD	1.7717" 1.7712"
HOUSING ID. OUTBOARD	3.9370" 3.9379"
	0.0015" loose 0.0000" loose
BEARING O.D. OUTBOARD	3.9370" 3.9364"

PUMP REASSEMBLY

BEARING INSTALLATION

1. Begin by cleaning your work area. Contaminants and debris can cause unnecessary bearing failures.
2. Clean all components thoroughly before proceeding with the new bearing installation.
3. If the shaft surface is marred, it must be cleaned and smoothed. Use a bearing warmer or warm the bearing in an oven to 180 degrees. This will expand the races so that the bearing may easily slide onto the shaft. Do not heat excessively, so as not to damage the bearing ball retainers. It would also be advantageous to cool the shaft at this time, to more easily slip the warmed bearing into position. Once the components are left to return to normal temperatures the fit will be assured.
4. If the bearing must be pressed onto the shaft, use an arbor press with sufficient stroke to complete the fit. The bearing maybe placed on a face block which contacts only the bearing inner ring and which has an internal diameter greater than the bearing bore.
5. The shaft is then positioned through the bearing until it is seated firmly against the shaft shoulder. If excessive force is required, check the shaft and the bearing inner tolerances before committing to a complete installation. When mounting the shaft to the bearing, the mounting force should be applied only against the race being fitted. A bearing should never be forced onto a shaft by pressure or hammer blows applied to the outer ring. Do not allow any misalignment the bearing and shaft during the installation process.
6. Adjust the impeller and shaft
7. Install the drive-coupling key, and remount the drive-coupling flange.
8. Place stem plate gasket (24) on stem.
9. Loosen locking and jack screws in the bearing frame.
10. Install rotating assembly in impeller housing (26).
11. Install and torque the housing assembly bolts.
12. Replace shims under frame heel and tighten frame to base plate. A dial indicator may be mounted to measure the distance between the top of the frame and the base plate. This measurement should not change as bolts are tightened,
13. Total travel of impeller in the casing should not exceed .030 in. Determine cause and correct before proceeding.
14. Adjust the impeller clearance.
15. Replace any piping; add proper lubricant(s) to the pump and seal cavity.
16. Check to assure the shaft will rotate easily. If so continue with startup If the shaft does not turn easily determine cause and correct.

POWER FRAME ASSEMBLY

1. Install the oil sight gauge, bearing frame breather, and oil drain plug in the bearing frame (13) and hand tighten.
2. Install the thrust bearing (5) on shaft (9).
3. Install snap ring (4) onto shaft.
4. Coat outside of thrust bearing (5) and the inside of bearing housing (6) with oil. Install bearing housing onto shaft/bearing assembly. Do not force assembly together,
5. Install thrust bearing retainer (2) Gasket (3), and bolts. Torque bolts per and check shaft for free turning.
6. Install radial bearing (10) onto shaft.
7. Install new o-ring (7) onto bearing housing (6).
8. Install oil seal (1) into thrust bearing retainer (2).
9. Coat outside of bearing housing (2) and all internal surfaces of bearing frame (13) with oil.
10. Install shaft assembly into bearing frame (13),
11. Install locking screws and adjusting screws with jam nuts, and hand tighten.
12. Attach pedestal (14) to bearing frame, hand tighten bolts.
13. Support the power frame in a horizontal position.
14. Check shaft end play limits [.0013/.0021"]. The shaft should move forward and back by hand.
15. Check shaft run out. Install shaft sleeve (16) and thread Impeller (26) onto shaft. Hand tighten, then rotate impeller one turn. If reading varies more than .002 in, disassemble power frame and determine cause. Remove impeller and shaft sleeve.
16. Check bearing frame race run out. Rotate shaft as indicator rides along face of frame for one turn. If reading varies more than .001 In. disassemble frame and determine cause.
17. Install stem (18) to bearing frame, Torque bolts, in an alternating pattern.
18. Check stem run out. Rotate shaft one turn, if reading varies more than .005", disassemble pump and determine cause.
19. Install oil seal (15) in bearing frame.
20. Install stem plate (23) to stem (18) (from Impeller end of pump), Check the stem plate run out. Rotate shaft one turn, if reading varies more than .005 in. determine cause and correct before continuing.
21. Install shaft sleeve (16) on shaft.
22. Thread impeller (25) with impeller o-ring (17) onto shaft.
23. Put shaft wrench on shaft and continue to thread impeller until it makes firm contact with sleeve.
24. Next, raise shaft wrench off work surface, then slam it back down onto work surface or a solid block. Repeat process a few times to tighten impeller.
25. Loosen locking and jacking screws in bearing frame. Using a feeler gauge adjust impeller until there is a .030" clearance between the impeller and stem plate. Tighten the jack screws, locking screws and jam nuts.
26. Check impeller run out. If total reading checked from vane tip to vane tip, varies more than .005 in., determine cause and correct before continuing.

7071 SERIES SHAFT RUNOUT TOLERANCES		
	SLEEVE FIT	COUPLING FIT
WITH SLEEVE	0.001	0.001
WITHOUT SLEEVE	0.002	0.001
7071 SERIES BOLT TORQUE VALUES		
	8"7071S	7071M
IMPELLER HOUSING BOLTS	20 FT-LBS	30 FT-LBS
	30 FT -LBS	45 FT LBS
BEARING FRAME TO STEM BOLTS	20 FT-LBS	30 FT-LB8

ASSEMBLY TROUBLESHOOTING

Problem	Cause	Solution
Excessive shaft end play.	Bearing internal clearance too great. Snap ring loose in housing groove	Replace bearings. Reseat snap ring
Excessive shaft run out.	Sleeve worn. Shaft bent.	Replace worn parts.
Excessive bearing frame run out.	Shaft bent. Bearing frame flange distorted.	Replace shaft
Excessive stem run out	Corrosion.	Replace worn parts
Excessive stem plate run out.	Stem plate not property seated Corrosion or wear	Reseat stem plate Replace worn parts

PARTS LISTINGS & SCHEMATICS

TO ORDER REPLACEMENT PARTS:

Identify the part(s) by item number using the pictorial schematic provided. Match the item number to the list, and identify the part required by stock number. Contact your **REINCO** dealer for price and availability. Parts may be ordered directly from the factory, outside of dealer territories. Parts ordered from the factory, for shipment to a customer within a dealer territory will be directed through the respective dealer's Parts and Service departments.

Many of the parts listed are commercially available and may be procured locally. Manufacturer's specific part numbers are available on request.

Other parts, such as engine components may be obtained through the respective manufacturer's distribution and service network.

Should you require assistance with regard to locating these agencies, contact your **REINCO** dealer or **REINCO** directly.

SAFETY OPERATIONS MAINTENANCE AND PARTS MANUALS

Additional user manuals may be ordered, using the following stock number:

PART NO.	DESCRIPTION
11304005	HG-13GX SERIES SAFETY, OPERATIONS, PARTS AND SERVICE MANUAL

DECALS AND LABELS

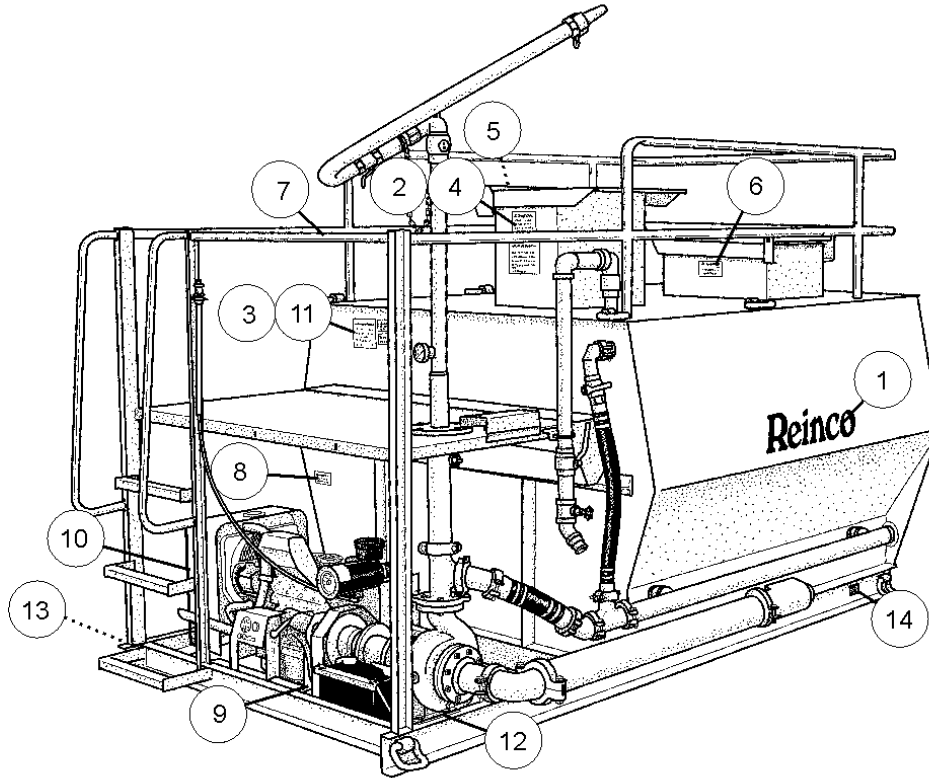

ITEM	PART NUMBER	DESCRIPTION	QTY
1	ID2526.03	APPLIQUE - REINCO LOGO	2
2	00171020	DECAL - HYDROGRASSER CHARGING SEQUENCE	1
3	00202000	DECAL - LUBRICATION SCHEDULE	1
4	00212010	DECAL - 'DANGER' ROTATING MACHINERY	1
5	00191000	DECAL - BEARING LUBRICATION	1
6	00251000	DECAL - 'WARNING' CONFINED SPACE	1
7	00171040	DECAL - SPRAY VALVE THROTTLING	1
8	00211020	DECAL - 'CAUTION' STOP MACHINE	1
9	00212030	DECAL - 'WARNING' MACHINE GUARD	1
10	00221000	DECAL - 'CAUTION' 2600 RPM	1
11	00301000	DECAL - HEARING PROTECTION	1
12	00171030	DECAL - PUMP IMPELLER CLEARANCE	1
13	ID2600.11	PLATE - MODEL AND SERIAL IDENTIFICATION	1
14	00241000	DECAL - REINCO SALES AND SERVICE '800'526-7687	1

PIPING COMPONENTS			
ITEM	PART NUMBER	DESCRIPTION	QTY
1	13572010	SUCTION MANIFOLD 5" x 59-3/4"	1
2	PI2350.50	SUCTION LINE ELBOW 5" x 90°	1
3	13731010	SUCTION FLANGE/ ADAPTER ASSEMBLY	1
4	PI7440.02	SUMP ADAPTER NIPPLE	1
4.1	S00590.01	VORTEX BAFFLE	1
5	PI2330.30	CLEAN OUT CAP	2
10	11083010	CIRCULATION MANIFOLD	1
11	PI2380.32	DISCHARGE LINE TEE	1
12	PI2351.30	DISCHARGE LINE ELBOW 3" x 45°	2
13	13731030	DISCHARGE/CIRC LINE HOSE ASSEMBLY	1
14	CA7275.00	HYDRO-JET NOZZLE (WEAR SLEEVE) CI	2
15	01501010	NOZZLE RETAINER NIPPLE	2
20	13723010	SPRAY BOOM STANDPIPE w/ FLANGE	1
21	JO4250.00X	SWIVEL JOINT ASSEMBLY 360°	1
22	00531010	SWIVEL STOP ASSEMBLY	1
23	CH0643.10	SNAP HOOK	1
26	VA5284.00	BALL VALVE 2"	2
27	PI7915.00	VALVE ADAPTER NIPPLE x CLOSE	1
28	PI2822.02	QUICK DISCONNECT ADAPTER 'F' (MALE)	1
30	GA8001.07	PRESSURE GAUGE (INTERNAL ISOLATOR)	1
40	03553025	SPRAY RETURN LOOP W/ COUPLERS	1
41	NO9982.01	NOZZLE 2" LONG RANGE SS	1
42	NO9982.02	NOZZLE 2" MEDIUM RANGE SS	1
43	NO9982.03	NOZZLE 2" FAN PATTERN SS	1
50	PI2310.20	LINE COUPLING 2" - #75 BOLTS & NUTS (W/ GASKET)	3
51	PI2311.20	LINE COUPLING 2" - #78 CAM (W/ GASKET)	1
52	GA7005.20	GASKET ONLY 2" H75E	4
53	PI2310.30	LINE COUPLING 3" - #75 BOLTS & NUTS (W/ GASKET)	5
54	PI2311.30	LINE COUPLING 3" - #78 CAM (W/ GASKET)	2
55	GA7005.30	GASKET ONLY 3" H75E	7
56	PI2310.50	LINE COUPLING 5" - #75 BOLTS & NUTS (W/ GASKET)	1
58	GA7005.40	GASKET ONLY 5" H75E	1
59	PI2312.54	REDUCING COUPLING 5" x 4" #7010	1
60	GA7007.54	GASKET ONLY 7010-E	1
63	PI2360.30	3" SPLIT FLANGE ASSY	1
64	GA7006.30	GASKET ONLY 3"	1
65	PI2312.32	REDUCING COUPLING 3" x 2" #7010	1
66	GA7007.32	GASKET ONLY 7010-E	1
70	13571030	GRINDER SUPPLY HOSE	1
71	PI2352.20	ADAPTER ELBOW 2" x 90° GxT	1
72	PI7320.02	TANK ADAPTER NIPPLE 2" GxG	1
80	PI2822.06	QUICK DISCONNECT COUPLER 'D' (FEMALE) W/ GASKET	2
81	GA7001.61	GASKET ONLY 2" x 1/4" NEOPRENE	2
90	GA7002.30	GASKET 3" FLANGE RING	1
91	GA7002.40	GASKET 4" FLANGE RING	1

SPRAY BOOM SWIVEL JOINT PARTS

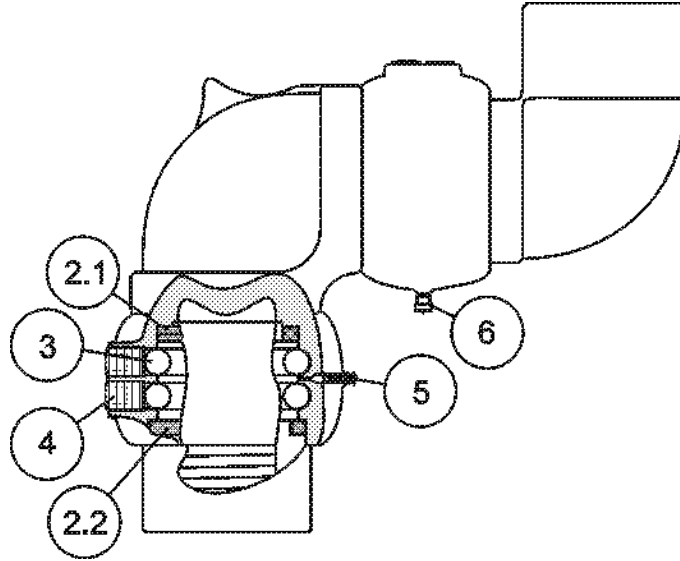

ITEM	PART NUMBER	DESCRIPTION	QTY
1	JO4250.00X	SWIVEL JOINT ASSEMBLY 2" STYLE 50 (360°)	1
2	JO4251.11	SEAL KIT 2"	1
2.1	SE0530.27	'QUAD' RING SEAL	2
2.2	SE0521.24	'O' RING SEAL	2
3	JO4251.02	BALL SET 3/8" x 54 pc	2
4	PI2832.01	SERVICE PORT PLUG	4
5	LU0712.06	LUBRICATOR (ALEMITE) FITTING	2
6	CP1010.02	LUBRICATOR CAP	2

REINCO HG-13GX3 HYDROGRASSER •SAFETY•OPERATION•SERVICE•PARTS MANUAL

GRINDER/BLENDER SYSTEM

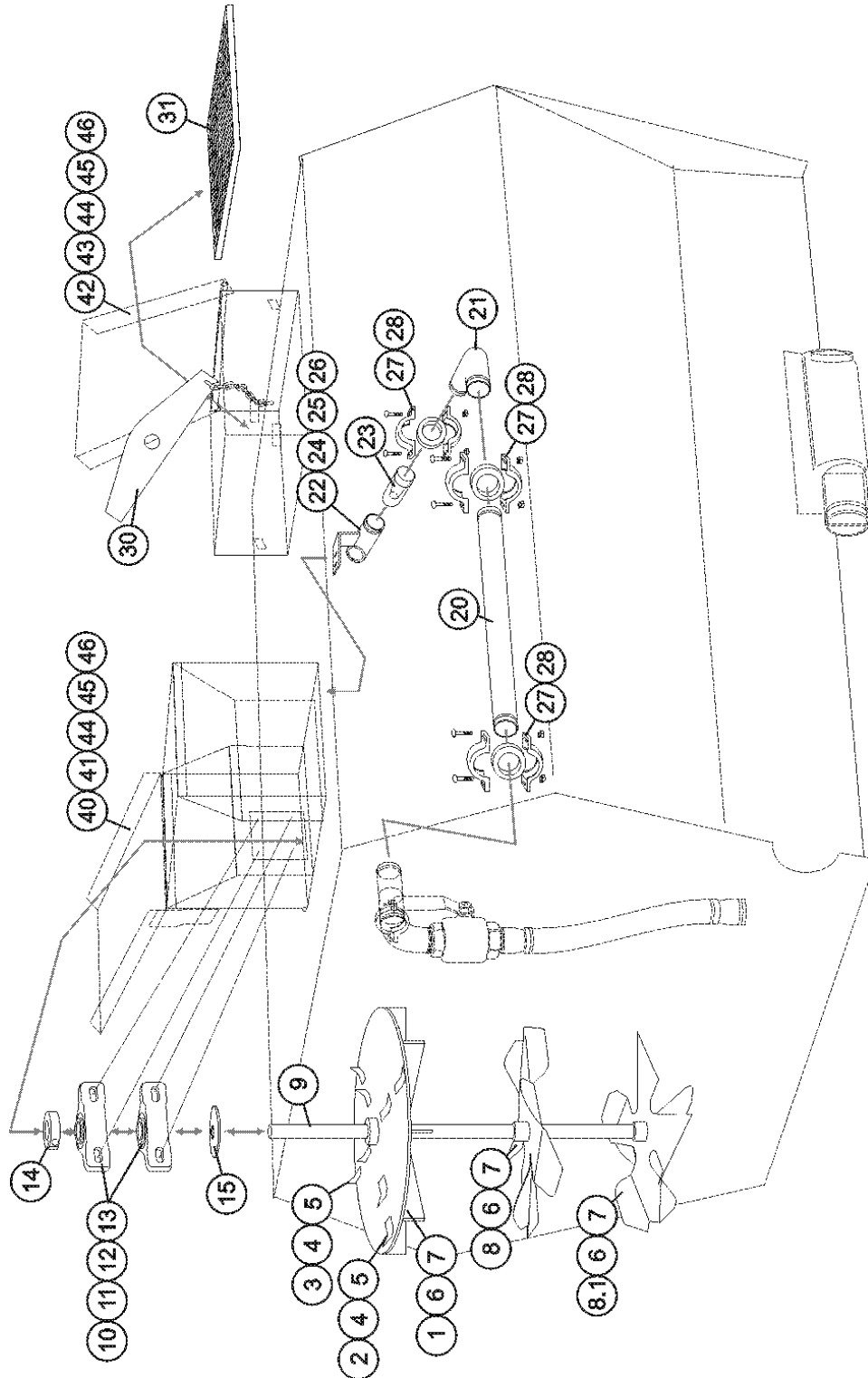

GRINDER/BLENDER SYSTEM PARTS LISTING

ITEM	PART NUMBER	DESCRIPTION	QTY
1	06575000	GRINDER/BLENDER DRIVE WHEEL	1
2	06573041	GRINDER TOOTH (RH PEAK)	4
3	06573042	GRINDER TOOTH (LH PEAK)	4
4	FA1124.06G8	5/16-18 x 3/4" HEX HEAD CAP SCREW- GRADE 8	16
5	FA0330.02	5/16" LOCK WASHER	16
6	FA1124.30	3/8-16 x 3" HEX HEAD CAP SCREW	3
7	FA1241.03	3/8-16 NYLON INSERT NUT	3
8	00781010	MIXED FLOW BLENDER – TOP	1
8.1	00781040	MIXED FLOW BLENDER – BOTTOM	1
9	06681010	GRINDER/BLENDER SHAFT	1
10	BE0240.01	BEARING 1-1/4" PILLOW BLOCK	2
11	FA1126.16	1/2-13 x 1-3/4" HEX HEAD CAP SCREW	4
12	FA0323.04	1/2" SAE WASHER	4
13	FA1241.04	1/2-13 NYLON INSERT NUT	4
14	BU7330.05	SHAFT LOCKING COLLAR	1
15	GA7001.13	SLINGER	1
20	PI6622.50	SUPPLY LINE PIPE 2" x 30" GBE-GALV	1
21	PI2350.20	SUPPLY LINE ELBOW 2" x 90° #10	1
22	01541010	HYDRO-JET NOZZLE RETAINER ASSEMBLY	1
23	01531000	HYDRO-JET NOZZLE 1" PORT	1
24	FA1124. 10	3/8-16 x 1" HEX HEAD CAP SCREW	2
25	FA0330.03	3/8" LOCK WASHER	2
26	FA0320.03	3/8" FLAT WASHER	2
27	PI2310.20	LINE COUPLING 2" - #75 BOLTS & NUTS (W/ GASKET)	3
28	GA7005.20	GASKET ONLY 2" H75E	3
30	03131030	BAG BREAKER W/ CHAIN	1
31	03151000	HATCH SCREEN	1
40	03112020	GRINDER HATCH LID/TRAY	1
41	03083030	GRINDER HATCH LID PIVOT BAR	1
42	03041000	ACCESS HATCH COVER	1
43	03144080	HATCH LID PIVOT BAR	1
44	HA7160.03	ROLL PIN 1/8" x 1"	4
45	SH7210.02	BUMPER	4
46	BU2308.04	PIVOT BAR BUSHING	4

ENGINE & PUMP DRIVE GUSHER PUMP

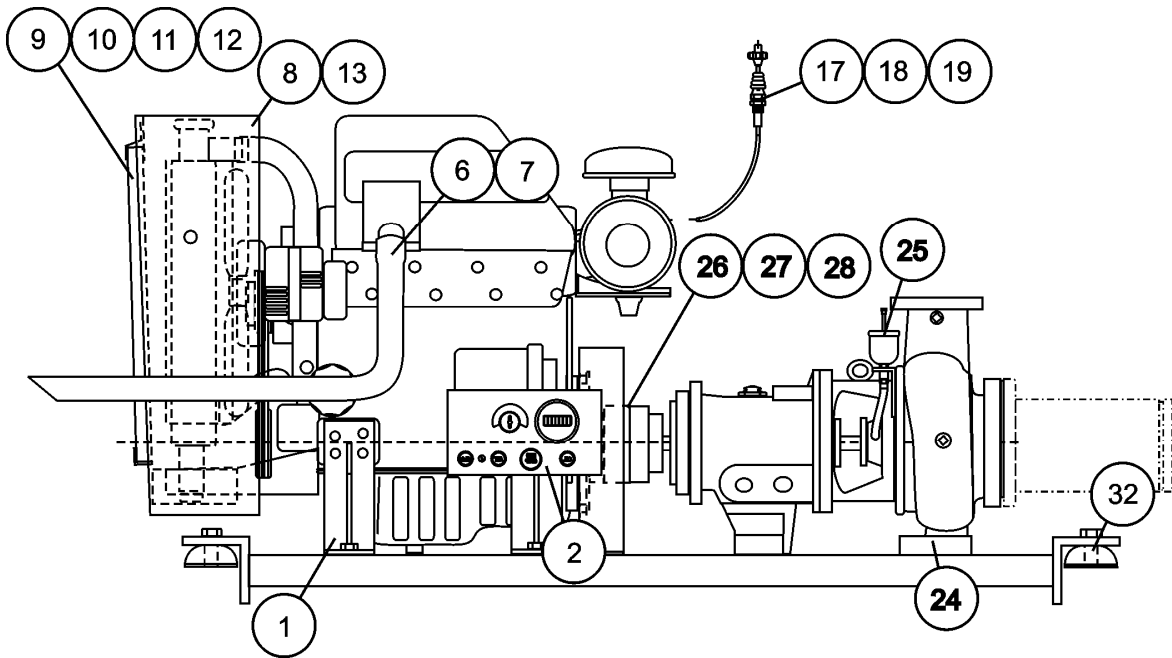

ITEM	PART NUMBER	DESCRIPTION	QTY
1	EN3116.10	ENGINE -KUBOTA V1505B1	1
1.1	EN3116.12	MANIFOLD MUFFLER #3756088513	1
1.2	11235010	COMMON ENGINE MOUNT	4
2	31521000	ENGINE INSTRUMENT PANEL	1
3	02593000	ENGINE WIRING HARNESS	1
6	EX3020.16	TAILPIECE 1-3/8	1
7	EX3060.14	EXHAUST CLAMP 1-1/2	1
8	07846000	RADIATOR ENCLOSURE	1
9	07892030	RADIATOR DEBRIS SCREEN	1
10	07846020	SCREEN HOLD DOWN BRACKET	1
13	SH6060.10	RADIATOR ISOLATOR MOUNT	2
24	PU5269.00	PUMP 3x4-8 SEH [8-1/4]	1
25	00551000	PUMP SEAL LUBRICATOR ASSEMBLY	1
25.1	LU0710.03	LUBRICATOR CUP ONLY	1
26	CO8512.30X	COUPLING ASSY HAYES #50 / 124273 - 1-1/8"B	1
27	KE9001.20	KEY - PUMP SHAFT 1/4x2 BER	1
28	11231040	FLYWHEEL COUPLING GUARD	1

COMMON ENGINE COMPONENT

ITEM	PART NUMBER	DESCRIPTION	QTY
2.1	IN3601.00	HOUR METER	1
2.2	EL2115.10	LAMP - RED (ALTERNATOR)	1
2.3	EL2115.20	LAMP - GREEN (OIL)	1
2.4	EL2115.30	LAMP - AMBER (TEMPERATURE)	1
15	32512000	FUEL TANK KIT	
15.1	01627010	TANK - 12 GALLON CAPACITY	1
15.2	01631010	FUEL TANK PICKUP	1
15.5	HO7303.11	FUEL HOSE /FT	4
15.6	HO7301.81	FUEL RETURN HOSE /FT	5
15.7	TA2010.12	FELT TAPE 1/8 x 1" /FT	1
17	CO6240.00	THROTTLE CONTROL CABLE ASSEMBLY	1
18	CO6297.01	PIVOT PIN ASSEMBLY	1
19	CO6120.05	THROTTLE BELLOWS	1
20	SI0901.05	SIGNAL HORN	1
21	02021000	HORN MOUNT	1
22	EL2101.61	FOOT PAD	1
29	BA8802.10	BATTERY 12V GROUP 30H	1
30	BA8806.02	BATTERY CABLE 30-31" (+)	1
30.1	BA8850.01	BATTERY TERMINAL BOOT-RED (+)	1
30.2	BA8807.01	GROUND STRAP	1
32	SH6055.01	FRAME COMPRESSION MOUNT	4

SIGNAL AND LIGHTING COMPONENTS

ITEM	PART NUMBER	DESCRIPTION	QTY
	SI0901.60	SIGNAL HORN 12V	1
	EL2101.61	FOOT SWITCH	1

PUMP – GUSHER 7071S ANSI A70

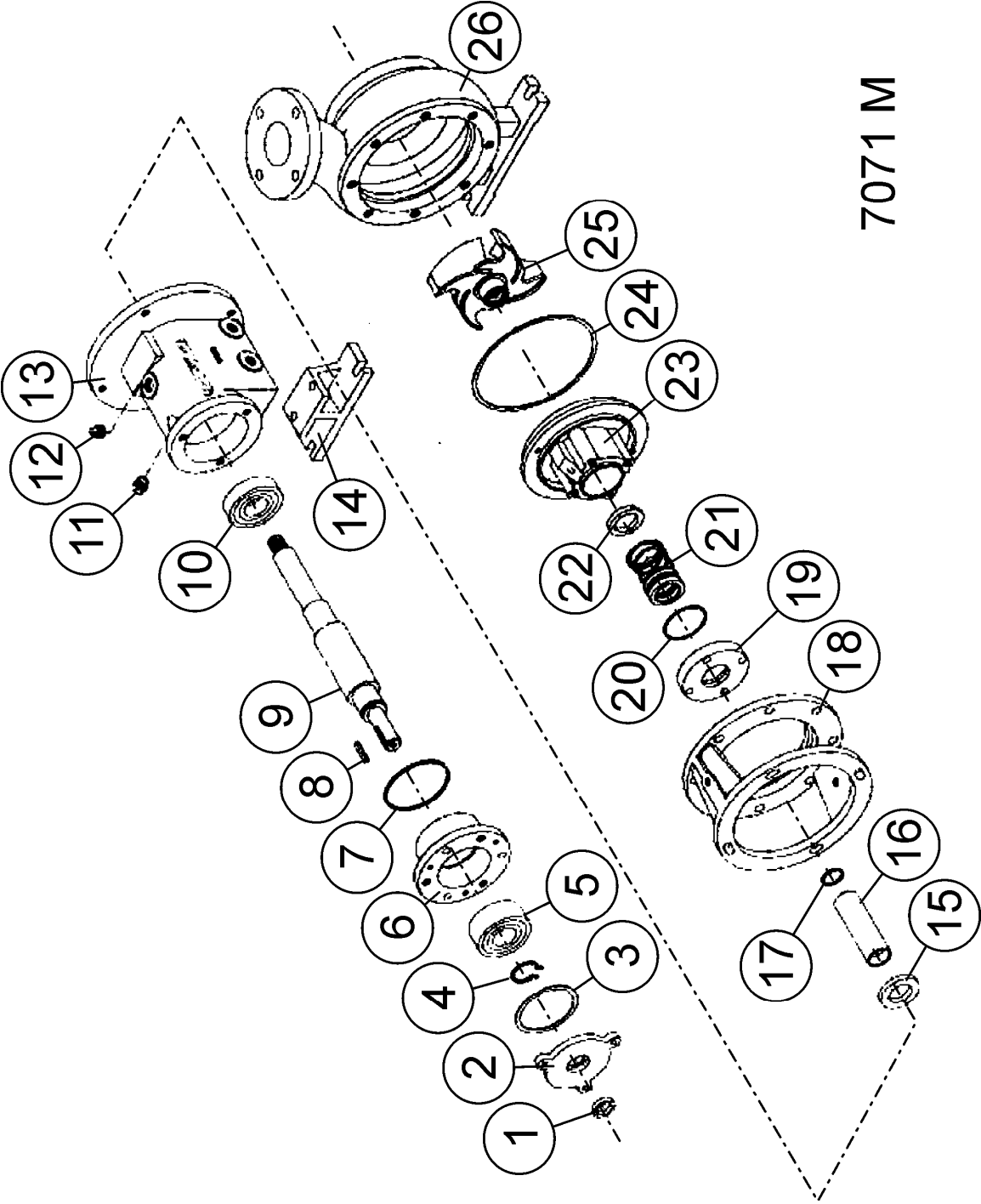

7071 M

PARTS LISTING - GUSHER A70

ITEM	PART NUMBER	DESCRIPTION		QTY
-	PU5269.00	Pump Assembly	CL3x4-8SEH-CBM- ANSI (A70)	
1	PU5269.58	Oil Seal (Coupling End)	83046	1
2	PU5264.55	Bearing Housing	14072-4	1
3	PU5269.02	Lock Nut		1
4	PU5264.56	Thrust Bearing(OB)	41309-DR-0	1
*5	PU5269.03	Snap Ring	5160175	1
6	PU5269.04	O-Ring - Bearing Housing (Teflon)	17028	1
7	PU5269.06	Drive Pin	71646	1
9	PU5269.51	Shaft	100046-CRS	1
10	PU5264.55	Radial Bearing (IB)	41309-0	1
*11	PU5269.64	Oil Sight Gauge	71245	1
*12	PU5269.63	Breather (Bearing Frame)	21628	1
13	PU5264.52	Frame (Bearing Support)	51072-CI	1
*14	PU5269.52	Pedestal	37000-CL	1
15	PU5269.61	Oil Seal (Bearing Frame)	83051	1
16	PU5264.59	Slinger	58052	1
*17	PU5290.12	Shaft Sleeve	63072-SS	1
18	PU5269.09	Stem	17133	1
*19	PU5269.10	Seal Gland	69171-1	1
*20	PU5269.13	Gasket (Seal Gland)	69072	1
21	SE0571.91	Double Mechanical Seal Assembly Cartridge		1
*22	PU5269.57	Locking Collar		1
23	PU5269.56	Stem Plate	21133	1
24	PU5269.59	Gasket (Stem Plate)	61109	1
25	PU5269.01	Impeller [8.25"Dia]	25108-DI	1
26	PU5269.05	Volute Housing (Impeller)	27108-DI	1

**ENGINE/PUMP DRIVE COUPLING ASSEMBLY
HAYES STYLE #50 FLYWHEEL TO SHAFT**

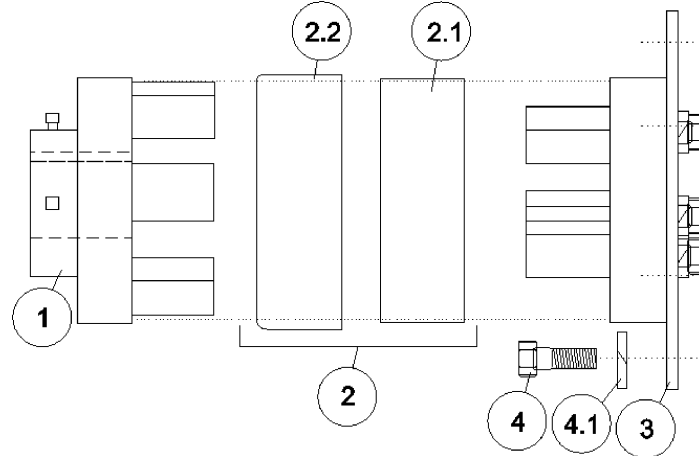

ITEM	PART NUMBER	DESCRIPTION	QTY
	CO8512.20X	COUPLING ASSEMBLY HAYES #50 / 124273 - 1-1/4"B	1
1	CO8446.28	COUPLING FLANGE #50 1-1/4" B x 3/8 Kw	1
2	CO8446.34	COUPLING INSERT w/ RING	1
2.1	CO8446.35	INSERT ONLY	1
2.2	CO8446.36	RING ONLY	1
3	CO8515.11	FLYWHEEL FLANGE ASSEMBLY #124273	1
4	FA3108.16	M8x1.25 x16MM HEX HEAD CAP SCREW	6
4.1	FA0330.02	SPLIT LOCKWASHER	6

FILL ASSEMBLY PIPING

ANTI-SIPHON FILL ASSEMBLY

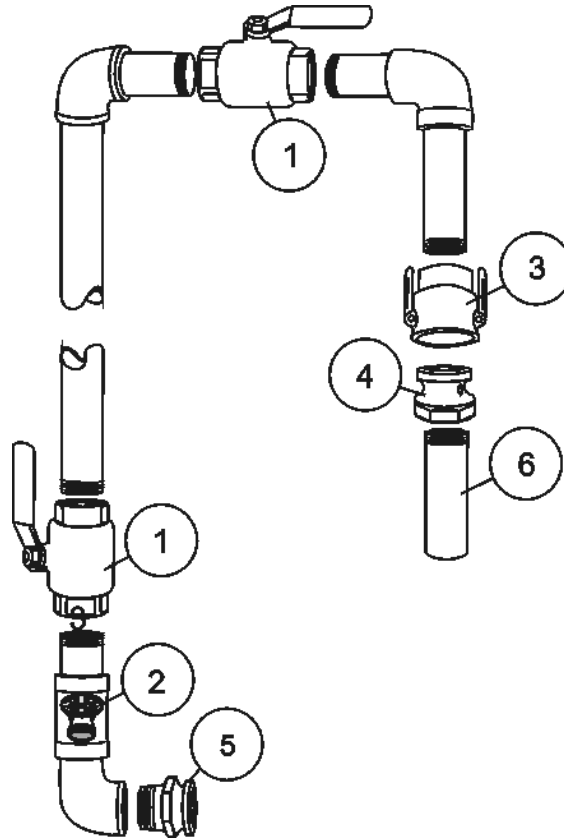

ITEM	PART NUMBER	DESCRIPTION	QTY
	11102010	AIR GAP FILL ASSEMBLY	
1	VA5286.00	BALL VALVE 2" FULL FLOW	2
2	VA5414.00	VALVE BIB (3/4" GARDEN HOSE)	1
3	PI2822.02B	QUICK-DISCONNECT ADAPTOR 'F'	1
4	GA6002.01	GASKET	2
5			1
5.1			1
6	HO7406.50	HOSE - 3/4" x 50' GARDEN HOSE MxFm	1

AIR GAP FILL ASSEMBLY

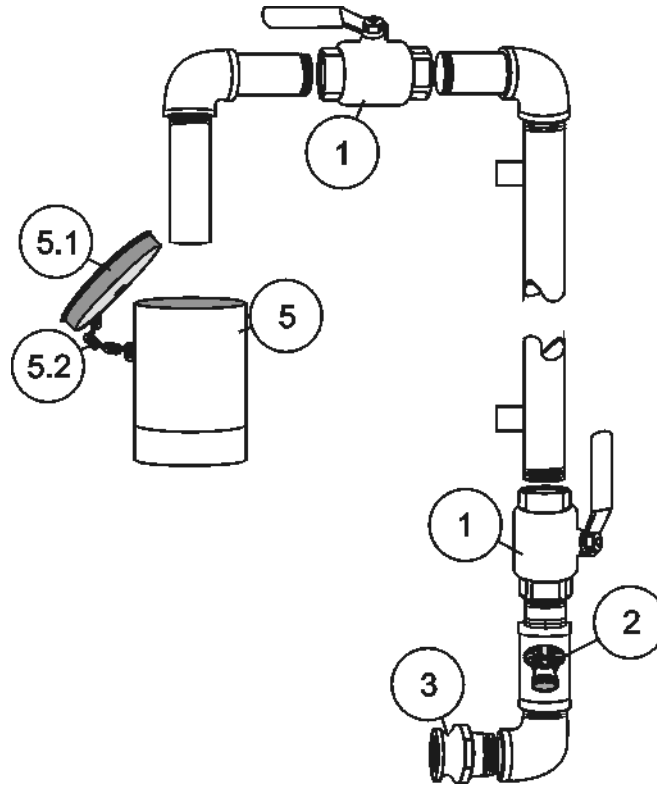

ITEM	PART NUMBER	DESCRIPTION	QTY
	11102010	AIR GAP FILL ASSEMBLY	
1	VA5272.00	BALL VALVE 1-1/2"	2
2	VA5414.00	VALVE BIB (3/4" GARDEN HOSE)	1
3	PI2821.52B	QUICK-DISCONNECT ADAPTOR 'F'	1
4	GA6002.01	GASKET	2
5	11111000	FILL RECIEVER (TANK MOUNT) w/CAP	1
5.1	11111001	RECIEVER CAP ONLY	1
6	HO7406.50	HOSE - 3/4" x 50' GARDEN HOSE MxFm	1

REMOTE HOSE REEL OPTIONS

ITEM	PART NUMBER	DESCRIPTION	QTY
1		HOSEREEL PACKAGE - ELECTRIC REWIND w/ HOSE 1-1/4" ID w/ RSV ASSY	
		HOSEREEL PACKAGE - ELECTRIC REWIND w/ HOSE 1-1/2" ID w/ RSV ASSY	
		HOSEREEL ONLY-ELECTRIC REWIND (NO HOSE)	
2	01103020	CONTROL BOX ASSEMBLY w/ ELECTRICALS	
	EL2104.10	CIRCUIT BREAKER 50A	1
	EL2103.02	SOLENIOD 3T 12V CONTINOUS DUTY	1
	EL2101.01	SWITCH w/ CAP - MOMENTARY	1
	FA0320.05	5/8" FLAT WASHER	1
	EL2201.01	CONTROL BOX ONLY 6x6x4 w/ SCREW COVER	1
	EL2202.10	LOCKNUT 3/4" EMT	1
	EL2202.02	STRAIN RELIEF CONNECTOR 1/2"	1
	EL2202.04	LOCKNUT 1/2" EMT	1
	01122000	SPLASH GUARD	1
3	03142000	BOOM/REEL SUPPLY HOSE - COUPLED CxC	1
4	HO7112.56	DISCHARGE HOSE 1-1/4"ID x 100FT COUPLED MxFm	
	HO7112.55	DISCHARGE HOSE 1-1/4"ID x 50FT COUPLED MxFm	
	GA7001.50	GASKET 1-1/4" HOSE COUPLING	
	HO7115.52	DISCHARGE HOSE 1-1/2"ID x 100FT COUPLED MxFm	
	HO7115.51	DISCHARGE HOSE 1-1/2"ID x 50FT COUPLED MxFm	
	GA7001.51	GASKET 1-1/2" HOSE COUPLING	
5	VA9911.25	REMOTE SPRAY VALVE ASSEMBLY 1-1/4"	
	VA5262.00	BALL VALVE 1-1/4" FULL FLOW	1
	PI2821.25B	QUICK-DISCONNECT COUPLER 'B' (ALUM) MALE NPT	1
	PI2821.22B	QUICK-DISCONNECT ADAPTOR 'F' (ALUM) MALE NPT	1
	PI2821.26B	QUICK-DISCONNECT COUPLER 'D' (ALUM) FML NPT	1
	GA7001.59	GASKET 1-1/4" QUICK-DISCONNECT COUPLER	
5	VA9911.50	REMOTE SPRAY VALVE ASSEMBLY 1-1/2"	
	VA5272.00	BALL VALVE 1-1/2" FULL FLOW	1
	PI2821.55A	QUICK-DISCONNECT COUPLER 'B' (NYL) MALE NPT	1
	PI2821.52A	QUICK-DISCONNECT ADAPTOR 'F' (NYL) MALE NPT	1
	PI2821.56A	QUICK-DISCONNECT COUPLER 'D' (NYL) FEMALE NPT	1
	GA7001.60	GASKET 1-1/2" QUICK-DISCONNECT COUPLER	
6	NO9940.00	NOZZLE 1-1/4" MEDIUM THROW (STRAIGHT STREAM)	1
7	NO9941.00	NOZZLE 1-1/4" NARROW FAN PATTERN(25° SPRAY)	1
8	NO9941.01	NOZZLE 1-1/4" WIDE FAN PATTERN (50° SPRAY)	1
6	NO9960.00	NOZZLE 1-1/2" LONG RANGE THROW (STR STREAM)	1
7	NO9960.01	NOZZLE 1-1/2" MED. RANGE THROW (STR STREAM)	1
8	NO9941.01	NOZZLE 1-1/2" FAN PATTERN (50° SPRAY ANGLE)	1

HOSE REEL PARTS

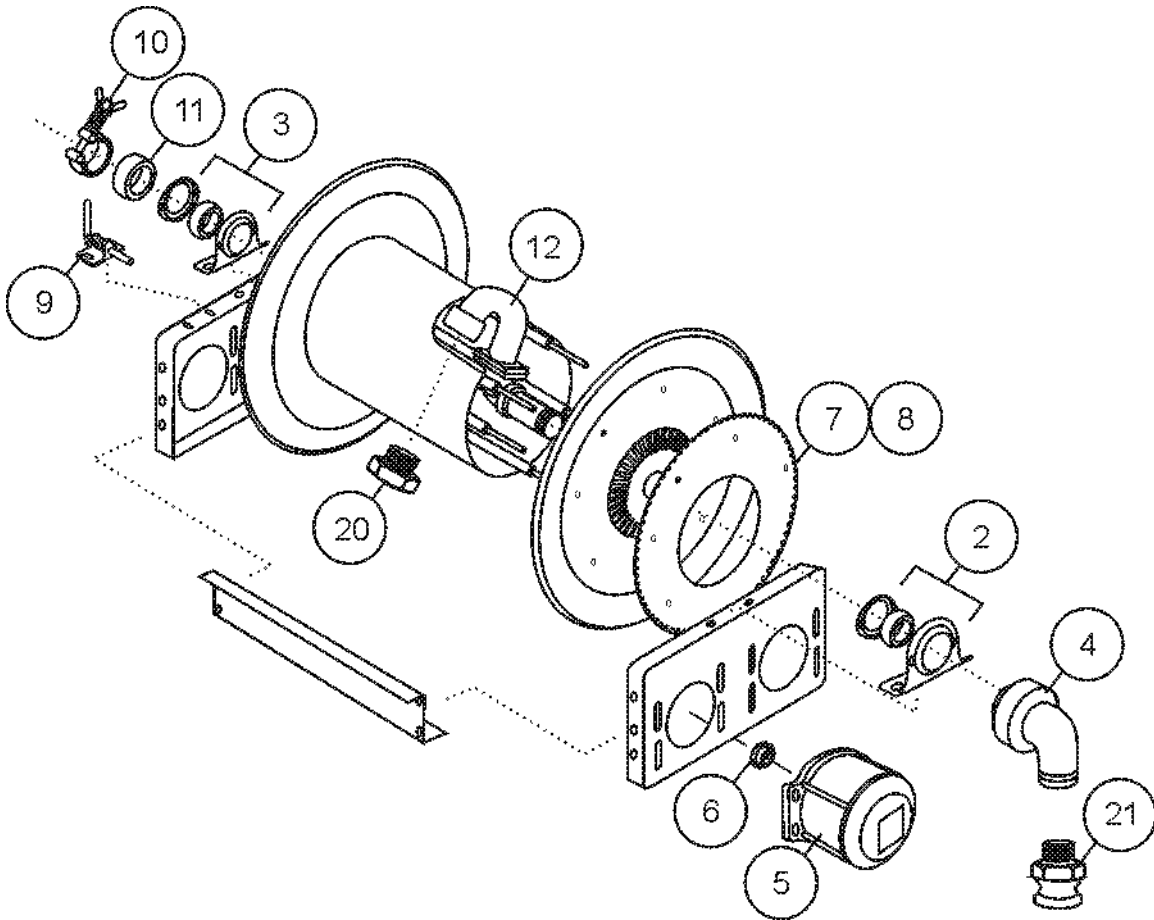

ITEM	PART NUMBER	DESCRIPTION	QTY
1	HR1000.20	HOSE REEL ASSEMBLY [ELECTRIC REWIND]	
2	HR1000.02	BEARING ASSEMBLY 1-1/2" #9902.1600	1
3	HR1000.03	BEARING ASSEMBLY 1" #9902.1400	1
4	JO4132.10	SWIVEL JOINT ASSEMBLY	1
5	MO8701.00	REWIND MOTOR 12V #9915.0003	1
6	SP2105.11	SPROCKET 11T 35 5/8"B #9910.1116	1
7	CH0647.00	CHAIN #35, 1/4" PITCH x 10' w/CONN.LINK #9912.0001	1
7.1	CH0647.01	CONNECTING LINK ONLY	1
8	HR1000.28	PIN LOCK ASSEMBLY #9965.0030	1
9*	PI2714.12	BUSHING 1-1/2" x 1-1/4"	1*
10*	PI7912.00	ADAPTOR NIPPLE 1-1/4" x CLOSE	1*
10	PI7913.00	ADAPTOR NIPPLE 1-1/2" x CLOSE	1
		*REQUIRED FOR 1-1/4" HOSE APPLICATION	
11	PI2822.15	SUPPLY HOSE QUICK DISCONNECT FITTING 2" 'F' x 1-1/2"NPT	1

HOSE REEL SWIVEL JOINT

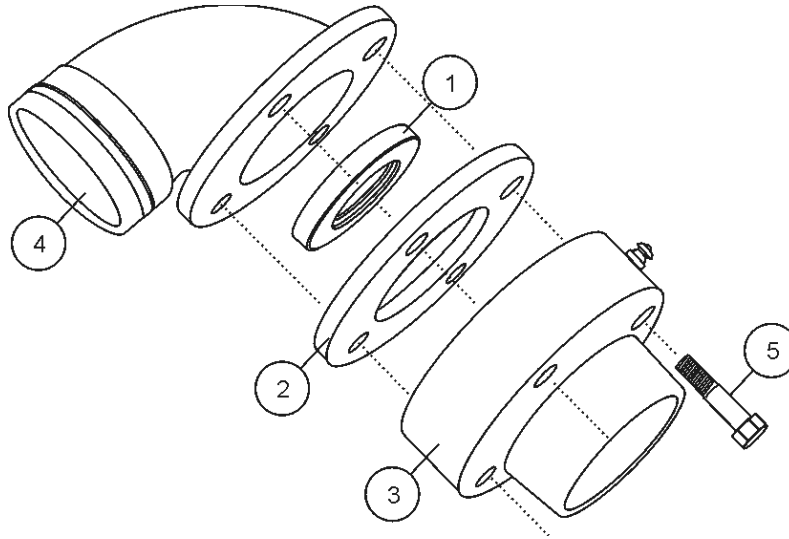

ITEM	PART NUMBER	DESCRIPTION	QTY
	JO4132.10	SWIVEL JOINT ASSEMBLY 1-1/2" x 90° #9930.4210	1
1	JO4132.11	SWIVEL JOINT REBUILD KIT #9936.0647	1
1.1		PACKING BUNA-N	1
1.2		BALL BEARING UNIT	1
1.3		SPACER-DELRIN	1
2	JO4132.12	SNAP RING #9938.0022	1
3	JO4132.13	GREASE RING w/ LUBR. FITTING #9938.0013	1
4	JO4132.14	ROTATING MEMBER #9938.0008	1
5	JO4132.16	BEARING RETAINER #9938.0016	1

OPTIONAL SPRAY BAR

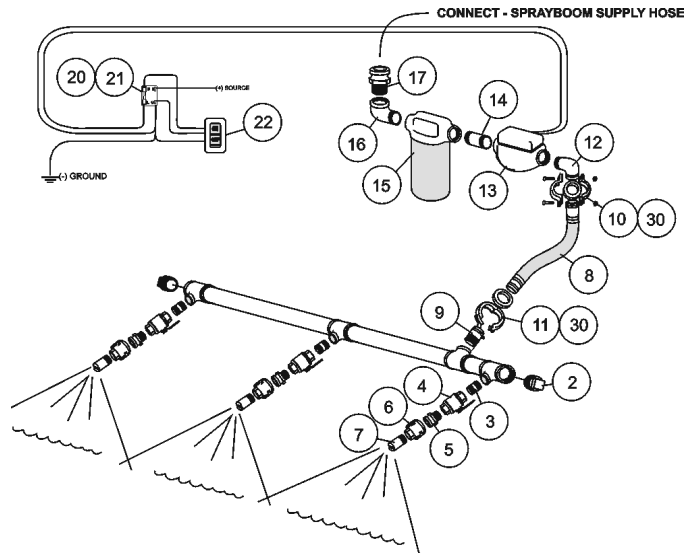

ITEM	PART NUMBER	DESCRIPTION	QTY
1	19092021	SPRAYBAR MANIFOLD ASSEMBLY	1
2	PI2831.21	PLUG 2" GALV	2
3	PI7910.00	NIPPLE 1" x CLOSE	3
4	VA5251.00	BALL VALVE 1" FULL FLOW	3
5	PI2821.02	QUICK-DISCONNECT ADAPTOR 1" 'F'	3
6	PI2821.06	QUICK-DISCONNECT COUPLER 1" 'D'	3
7	NO9901.42	NOZZLE 1" VEEJET #1U50580	3
8	19092022	SUPPLY HOSE w/ FITTINGS (SPECIFY LENGTH)	
8.1	HO7120.01	HOSE ONLY 2" x FT (SPECIFY LENGTH)	
8.2	PIU2825.20	HOSE FITTING #48 2" GRV x 2" HOSE SHANK	2
8.3	HO8002.01	HOSE CLAMP J209 SS	2
9	PI7520.03	ADAPTOR NIPPLE 2" x 2" GxT	1
10	PI2310.20	LINE COUPLING 2" #75 w/ GASKET (BOLT & NUTS)	1
11	PI2311.20	LINE COUPLING 2" #78 w/ GASKET (CAM)	1
12	PI2352.20	ADAPTOR ELBOW 2" #18 GxT	1
13	VA7020.00	SOLENOID VALVE 2" 12V #136A47W	1
14	PI7875.00	ADAPTOR NIPPLE 2" x CLOSE	1
15	ST7003.20	STRAINER ASSEMBLY 2" x 150#	1
15.1	ST7003.21	STRAINER ELEMENT #50 MESH	1
16	PI2853.20	ELBOW 2" x 90° STREET	1
17	PI2822.02	QUICK-DISCONNECT ADAPTOR 2" 'F'	1
18	PI2822.07	QUICK-DISCONNECT CAP 2"	1
20	EL2102.03	RELAY 12V 20A	1
21	EL2112.20	FUSE 20A AGC 32VDC	1
22	EL2101.40	TOGGLE SWITCH 12V- ROCKER RED	1
30	GA7005.20	GASKET ONLY 2" H75E	2

NOTES

