

# M-65

## POWER MULCHER

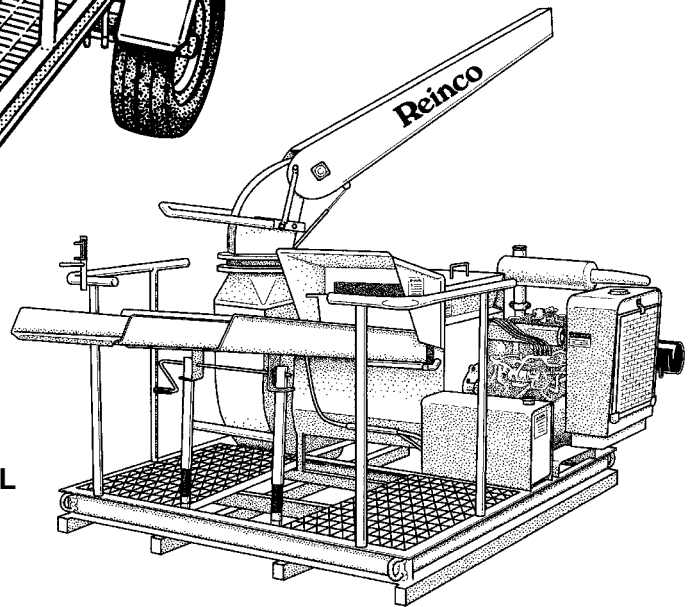
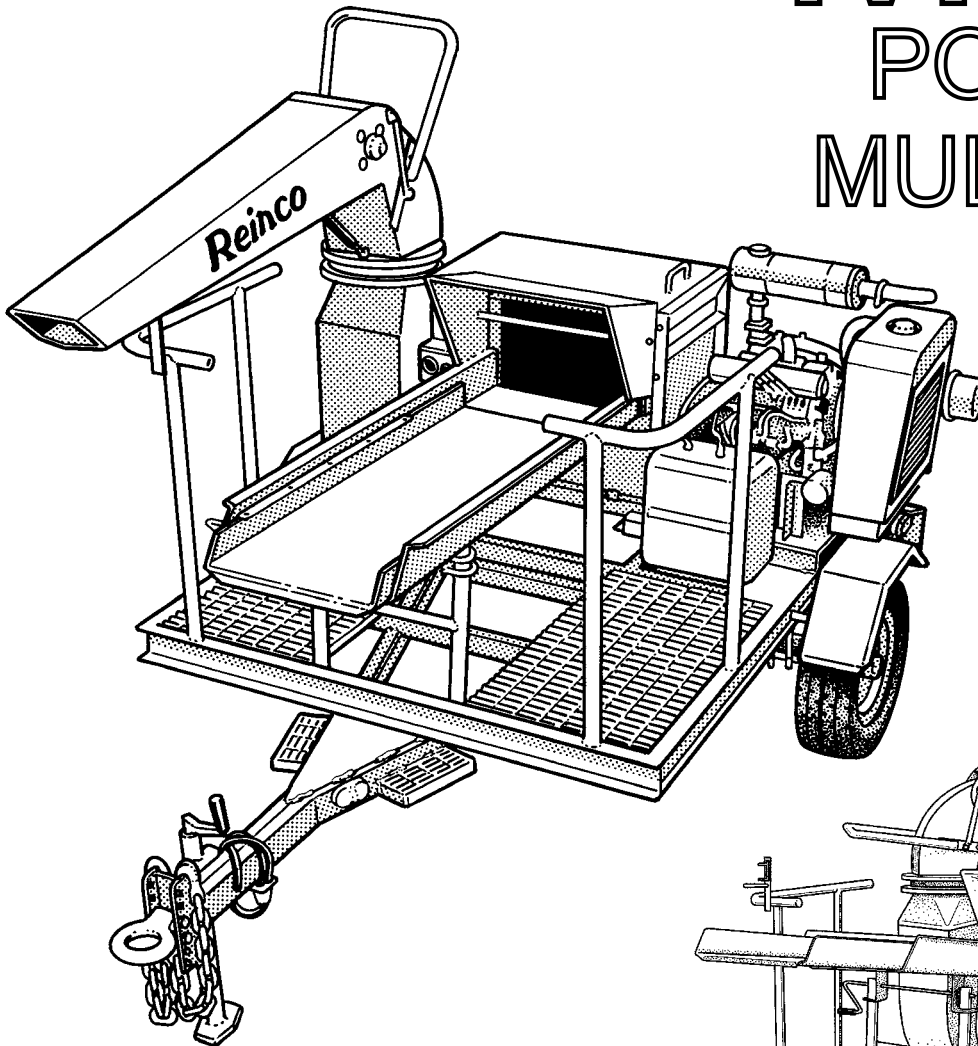

- 56 HP DIRECT DRIVE WATER COOLED DIESEL
- RATED 10 TONS PER HOUR MULCH OUTPUT
- 85 FOOT DIRECT DISCHARGE IN STILL AIR
- DISCHARGE HOSE PLACEMENT OPTION
- FMVSS STANDARDS HEAVY DUTY TRAILER
- OPTIONAL BRAKE AND HITCH CONFIGURATIONS
- SKID MOUNT VERSION MINIMIZES VEHICLE REQUIREMENTS
- EXCLUSIVE TWO-YEAR WARRANTY

# Reinco

Power Mulching & Hydrograssing Machinery  
Reinco Inc. • PO Box 512 • Plainfield, NJ 07061-0512

www.reinco.com  
Phone (800) 526-7687  
Local (908) 755-0921  
Fax (908) 755-6379

# POWER MULCHER • MODEL M65

The Reinco M-65 Power Mulcher is ideal for medium to large production sites with bale capacity for up to ten tons of hay or straw per hour, and placement of up to 85 feet. This rugged, high performance machine features improved mulch separation offering high production rates even with poor quality mulches. The sturdy, two-piece fully adjustable feed tray extends to speed mulch delivery to the placement operator. Five acres or more can be mulched in an hour or less. Combining over forty years of experience in this specialized field, Reinco's commitment to customer service, and with an industry leading two-year power mulcher warranty, your satisfaction can be assured.

## FEATURES

Manually fed flakes of average dry mulch results in an output of up to 10 tons per hour. Boom discharge range in still air is 85 feet.

Patented high volume beater drum (thrashing chamber) with raised inlet is contoured to eliminate debris kick back and configured to place flailing stations below line of sight.

The M-65 is a self-contained, portable machine, consisting of electrically welded modular components secured with plated self-locking fasteners, mounted on a fabricated steel base.

Engine power is reliably transmitted directly via flexible coupling to the blower. Our proven direct drive eliminates chains, belts, or clutches, and puts all the engine power to work! Fully adjustable flail stations are mounted in common on the heavy duty beater shaft. Access for flail adjustment is through hinged drum panel.

Formed cold finish steel discharge boom with center pivot bearings and formed handle bar with gas charged counter-balance spring provides responsive 60° control of vertical placement. Discharge assembly mounts to heavy-duty ball bearing slew assembly for unrestricted 360° horizontal rotation. Rolling polyurethane top and bottom seals with stainless steel side wipers insure operator comfort. Extendible two piece feed tray extends and locks in position to adapt to various tailgate overhangs, then retracts for storage and transport.

Four cylinder, heavy-duty water cooled, emissions certified, diesel engine, equipped with 12v ignition, battery, alternator and starter, and two-year manufacturer commercial engine warranty. Supplied with dual element dry type air cleaner, governor and chaff screen as standard. Keyed ignition, hour meter, ammeter, oil pressure and coolant fault lamps are cluster mounted on the engine panel. A quick setting venier type, weather-proof throttle is mounted for operator access. Foot operated signal horn provides on site communication between vehicle operator and crew. Fuel tank capacity is 12 gallons.

Trailer frame offers fixed work deck with galvanized grip strut slip free footing and 40" safety railings. Single 5200 pound, leaf spring mounted axle, and 15" 8 ply belted radial tires comprise the running gear. Adjustable lunette eye draw bar coupler, safety chain, 1000 lb. swing jack, fenders, bumper, DOT recommended lighting, FMVSS vehicle identification and wiring connector to tow vehicle are standard. Machine primed and sanded, then finished with Reinco lead free yellow modified acrylic final topcoat. Accessories are furnished plated or finish painted; complete with operating and safety decals.

All Reinco machinery is factory inspected and shipped assembled ready to work.

Call about your specific application requirements!

# Reinco

**Power Mulching & Hydrograssing Machinery**  
Reinco Inc. • PO Box 512 • Plainfield, NJ 07061-0512

SPECIFICATIONS SUBJECT TO CHANGE WITHOUT NOTICE

## SPECIFICATIONS

### SIZE:

**TRAILER:** 11'-10" (3.6 m)L, 7'-11 ½" (2.4m)W, 7'-2" (2.2 m)H  
**SKID:** 8'-9" (3.0 m)L, 8'-0" (2.4 m)W, 6'-0" (1.8 m)H

### WEIGHT:

**TRAILER:** Standard unit weight is 2400 pounds (1220 kg).  
Uncrated volume is 673 ft.<sup>3</sup> (19 m<sup>3</sup>).  
**SKID:** Standard unit weight is 2200 pounds (998 kg).  
Uncrated volume is 427 ft.<sup>3</sup> (13 m<sup>3</sup>).

### ENGINE:

Standard 56 HP water cooled EC Kubota Diesel.

### DRIVE:

Direct flexible insert spline type drive coupling.

### FLAIL:

Four adjustable full hardened chain flail stations.

### BLOWER:

26-1/8" OD six blade reinforced material handling type wheel, dynamically and statically balanced.

### DISCHARGE

Heavy-duty slew bearing mounted, gas charged spring counter-balanced, with center mount bearings, 360° horizontal rotation, 60° vertical articulation, urethane abrasion resistant boom seals and stainless steel side wipers.

### FEED TRAY:

Locking two-piece assembly extends and locks in 5 positions 70" to 110" from drum entrance. Elevation by synchronized twin jack system 51" (closed) to 77-1/2" (fully extended).

### TRAILER:

**STANDARD:** Structural straight frame type, 5200 lb. pre-cambered axles with steel shackle type spring assembly, 1000 lb. swing jack, full FMVSS lighting, 6 conductor trailing connector, 12,000 lb. GTWR lunette style hitch, adjustable 17.5", 22", 26.5".  
Tires are ST225/75R15 8 ply radial. Tongue weight 230 lbs.

### HOSE PLACEMENT:

Discharge kit includes 25 ft. of 8" helically wound, flexible urethane cuffed hose, boom adapter and hand held playpipe for extended placement. Connect additional 25 ft. hose sections to accommodate hard to reach areas.

### SEED DISTRIBUTOR:

2 bu. broadcast type distributor provides uniform placement of dry granular materials for simultaneous seeding and fertilizing.

### OPTIONAL EQUIPMENT

Tandem Trailer Package  
Electric or Hydraulic Brake axle(s)  
2-5/16" Adjustable Ball hitch

[www.reinco.com](http://www.reinco.com)  
Phone (800) 526-7687  
Local (908) 755-0921  
Fax (908) 755-6379

M65\_SP8 03/06G