

# TM-35

## POWER MULCHER

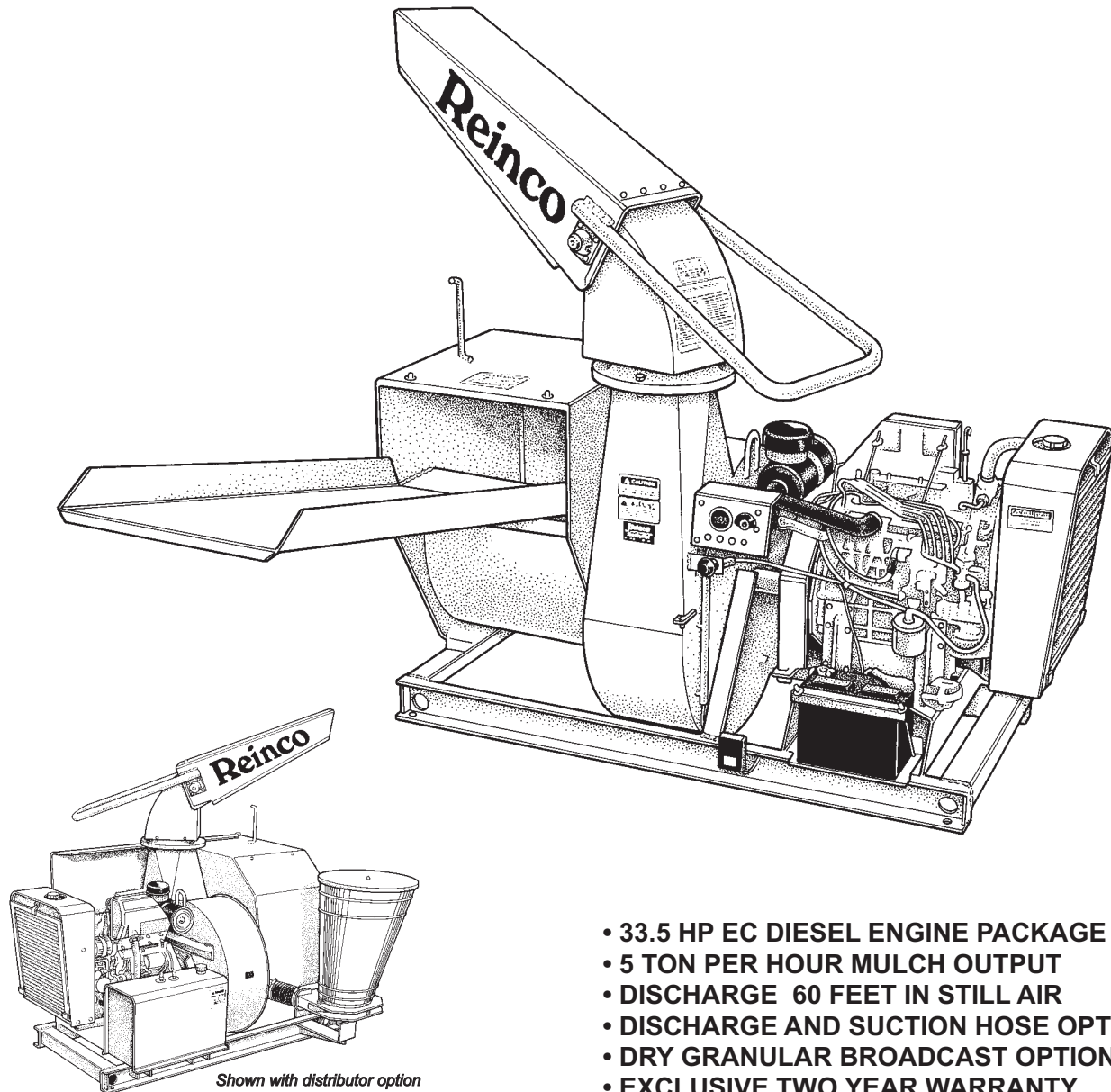

*Shown with distributor option*

- 33.5 HP EC DIESEL ENGINE PACKAGE
- 5 TON PER HOUR MULCH OUTPUT
- DISCHARGE 60 FEET IN STILL AIR
- DISCHARGE AND SUCTION HOSE OPTIONS
- DRY GRANULAR BROADCAST OPTION
- EXCLUSIVE TWO YEAR WARRANTY

# Reinco

Power Mulching & Hydrograssing Machinery  
Reinco Inc. • PO Box 512 • Plainfield, NJ 07061-0512

Phone (800) 526-7687  
Local (908) 755-0921  
Fax (908) 755-6379  
[www.reinco.com](http://www.reinco.com)

# POWER MULCHER • MODEL TM-35

The Reinco TM-35 Power Mulcher will rival the output of larger machines with rated bale capacity for up to five tons of hay or straw per hour and direct discharge of 60 feet. This rugged, high performance machine features a patented high load beater drum configuration for improved mulch separation and high productivity rates. Two to three acres or more can be mulched in an hour or less. With optional accessories this machine can be used year round for leaves and light debris cleanup and placement of other landscape materials. For years of dependability, demand Reinco Power Mulching machinery!

## FEATURES

Manually fed flakes of average dry mulch results in an output of up to five tons per hour. Direct discharge range in still air is 60 feet.

Patented high volume beater drum (thrashing chamber) with raised inlet is contoured to eliminate debris kick back and configured to place flailing stations below line of sight.

The TM-35 is a self-contained portable machine consisting of electrically welded modular components secured with plated self-locking fasteners, mounted on a fabricated steel base.

Engine power is reliably transmitted directly via flexible insert drive coupling to the blower. Our proven direct drive eliminates chains, belts, or clutches, and puts all the engine power to work! Fully adjustable flail stations are mounted in common on the heavy-duty beater shaft. Access for flail adjustment is through removable rear drum panel.

Formed cold finish steel discharge boom with center pivot bearings and heavy formed handle bar provides responsive 60° control of vertical placement. Discharge assembly mounts to self-lubricating nylon slew bearing for unrestricted 360° horizontal rotation. Rolling polyurethane top and bottom seals with stainless steel side wipers insure operator comfort.

Removable single section feed tray nests to feed mulch to thrashing chamber, then easily mounts and locks to the beater drum for storage and transport.

Four cylinder, heavy-duty, water cooled engine, equipped with 12V ignition, battery, alternator and starter, and two-year manufacturer commercial engine warranty. Supplied with dual element dry type air cleaner, governor and chaff screen as standard. Keyed ignition, hour meter, ammeter, oil pressure and coolant fault lamps are cluster mounted on the engine panel. A quick setting vernier type, weather-proof throttle is mounted for operator access. Foot operated signal horn provides on-site communication between vehicle operator and crew. Fuel tank capacity is 12 gallons.

Machine primed and sanded, then finished with Reinco lead free yellow modified acrylic final topcoat. Accessories are furnished plated or finish painted; complete with operating and safety decals.

All Reinco machinery is factory inspected and shipped assembled ready to work.

*Call about your specific application requirements!*

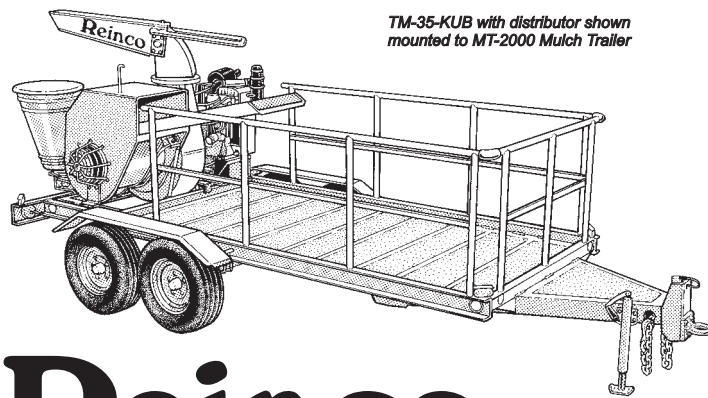

TM-35-KUB with distributor shown  
mounted to MT-2000 Mulch Trailer

## SPECIFICATIONS

### **SIZE:**

Length 79" (2.1 m), Width 44" (1.12 m), Height 64-1/2" (1.7 m).

### **WEIGHT:**

Standard unit weight is 1200 pounds (435 kg).  
Uncrated volume is 150cu. feet (4.24 cu. m).

### **ENGINE:**

Standard 33.5 HP Water Cooled EC Kubota Diesel.

### **DRIVE:**

Direct flexible insert drive coupling features easy access replacement bushings.

### **FLAIL:**

Three fully adjustable full hardened chain flail stations.  
Optional flail knives make easy work of tough materials.

### **BLOWER:**

22-5/8" OD six blade reinforced material handling type wheel, dynamically and statically balanced.

### **DISCHARGE:**

UMHW nylon bearing mounted, counter balanced, 360° horizontal rotation, 60° vertical articulation, urethane abrasion resistant rolling boom seals and stainless steel side wipers.

### **FEED TRAY:**

Single section extends 50" from drum entrance. Tray elevation from truck bed is 41".

## OPTIONAL EQUIPMENT

### **HOSE PLACEMENT:**

Remote discharge kit includes 25 ft. of 8" helically wound, flexible urethane cuffed hose, boom discharge adapter and hand held discharge playpipe. Connect additional 25 ft. hose sections to accommodate hard to reach areas.

### **SUCTION KIT:**

Adapter kit converts beater drum to suction chamber for leaf, mulch and light debris pick-up. Attach up to 50 ft. of 8" hose. The discharge playpipe is designed to double as a pick-up nozzle.

### **SEED DISTRIBUTOR:**

2.0 bu. broadcast type distributor provides uniform placement of dry granular materials for simultaneous seeding and fertilizing.

### **FORKLIFT FRAME:**

Sturdy formed steel and electrically welded frame provides for moving the machine around sites where accessibility is limited. Provides easy pickup from end or side of machine.

## THE COMPLETE REINCO PRODUCT LINE:

### **POWER MULCHERS:**

5 Models, 1-1/2 to 20 tons per hour mulch output.

### **HYDROGRASSERS:**

8 Models, 200 to 3000 gallon working capacity.

### **TRACER™ Tackifier products:**

Tack over hay/straw or as a binder for fiber mulch.

# Reinco

**Power Mulching & Hydrograssing Machinery**

Reinco Inc. • PO Box 512 • Plainfield, NJ 07061-0512

SPECIFICATIONS SUBJECT TO CHANGE WITHOUT NOTICE

Phone (800) 526-7687

Local (908) 755-0921

Fax (908) 755-6379

[www.reinco.com](http://www.reinco.com)

M35\_SPC0209G