

HG-30GX3

HYDROGRASSER

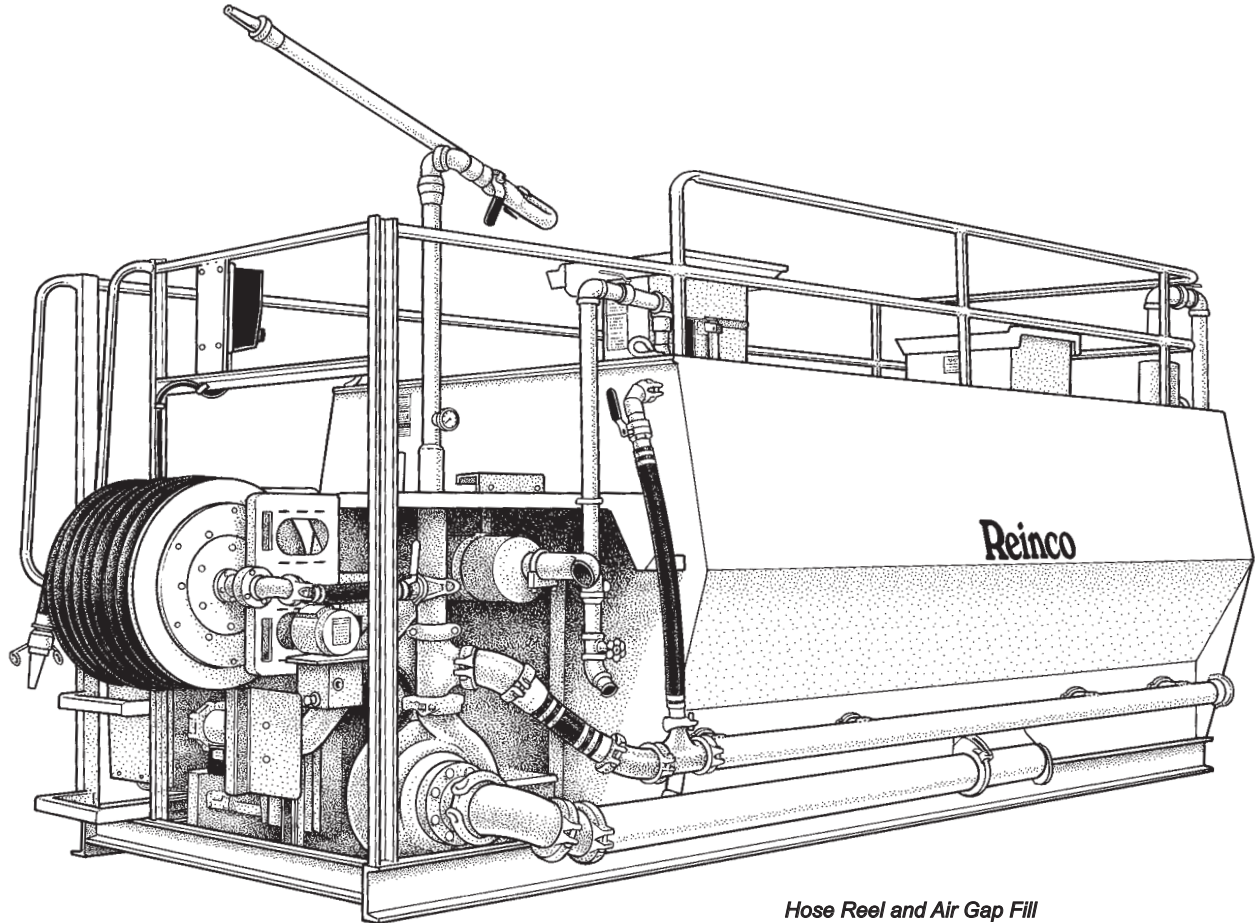

*Hose Reel and Air Gap Fill
Options Shown*

- 3500 GALLON TOTAL SLURRY VOLUME
- 99 HP EMISSIONS CERTIFIED TURBO DIESEL
- ALL IRON ANSI CENTERLINE DISCHARGE PUMP DESIGN MINIMIZES MAINTENANCE REQUIREMENTS
- EXCLUSIVE FIBER MULCH GRINDER/BLENDER SYSTEM OFFERS FAST LOADING OF CHARGED MATERIALS
- ANTI SIPHONING FILL ASSEMBLY IS STANDARD

Reinco

Power Mulching & Hydrograssing Machinery
Reinco Inc. • PO Box 512 • Plainfield, NJ 07061-0512

Phone (800) 526-7687
Local (908) 755-0921
Fax (908) 755-6379
www.reinco.com

HYDROGRASSER • MODEL HG-30GX3

With up to 6 acres coverage capacity in a single tankload, the Reinco HG-30GX3 Hydrograsser offers high productivity. Simplicity of design keeps maintenance costs to a minimum. The proven 'Hydro-Jet' agitation system assures a uniform mix throughout the entire load. Two large hatches provide for fast, simultaneous materials charging. Materials are mixed as quickly as they are loaded, and ready to spray in minutes. For years of dependability, demand Reinco Power Mulching and Hydrograssing machinery!

FEATURES

The unique Reinco 'Hydro-Jet' primary agitation system produces a violently turbulent circulating action to consume materials as they are loaded. Dual charging hatches allow for simultaneous loading of batch materials. Combining the exclusive 'Mulch Grinder' to shred mulch bales, with secondary 'Multiflow Blenders', charged materials are quickly incorporated into a completely homogenous slurry mix.

Engine power is reliably transmitted via flexible coupling directly to the axially adjustable all iron ANSI centerline discharge centrifugal pump, to combine mixing, recirculation and discharge via common manifold system. This proven system eliminates the high maintenance components of other systems. A novice can operate the machinery as easily as the seasoned professional.

The tank is formed and fabricated of 3/16" carbon steel sheet with 1/4" structurally reinforced end plates. Tank level markers are placed at 500 gallon increments on interior tank wall. Frame and modular components are formed and fabricated from carbon steel sheet and structurals, and welded throughout. Piping consists of electrically welded steel components featuring predominantly grooved mechanical pipe ends, drain and clean out connections supplied with cam style couplings for easy servicing. Ladder and safety railings are fabricated integrally to the completed machine. Standard anti-siphon fill prevents back flow to water source. Optional Air Gap Fill assemblies are available for specific application requirements.

The new ANSI centerline discharge pump provides superior performance with reduced horsepower requirements. The oil filled pump frame and double mechanical seal reduce maintenance to a bare minimum.

Power is provided from a five cylinder, heavy duty water cooled, emissions certified diesel engine, rated 99HP @ 2800 RPM. 12V ignition, battery, alternator and starter, fuel filter, two-stage dry evacuator type air cleaner, governor and chaff screen are standard. Fuel tank capacity is 30 gallons. Keyed ignition, Murphy PowerView™ J1939 CAN LCD graphical display instrumentation offers complete electronic engine monitoring and quick setting vernier type, weatherproof throttle are mounted for operator access. A foot operated signal horn, provides audio signaling for vehicle driver and crew.

The entire machine is primed, sanded and finished with durable lead free Reinco yellow modified acrylic enamel. Tank interior is coated with high solids aluminized epoxy. Platform area and tank top are provided with anti-slip coating. Operational and safety decals complete the installation.

All Reinco machinery is factory tested and shipped complete and ready to work.

Call about your specific application requirements!

Reinco

Power Mulching & Hydrograssing Machinery
Reinco Inc. • PO Box 512 • Plainfield, NJ 07061-0512

SPECIFICATIONS SUBJECT TO CHANGE WITHOUT NOTICE

SPECIFICATIONS

CAPACITY:

3000 Gallons (11,340 l) working volume (water).
3500 Gallons (13,230 l) total volume (combined slurry).
Granular solids: 10,000 lbs. (4,536 kg).
Processed Fiber Mulch: Up to 1500 lbs. (680 kg).

EFFECTIVE RANGE:

160 feet (49 m) from platform. 350 feet (107 m) with ext. hose.

SKID MOUNT:

Length 18'-8" (5.7 m) w/reel option 20'-11" (6.4 m),
Width 7'-11" (2.4 m), Height 8'-10" (2.7 m). Vol. 1,302 ft.³ (36.9 m³).
Weight 8,500 lbs. (3,850 kg). Fully charged 41,020 lbs. (18,607 kg).

ENGINE:

99 HP 5 cyl, water-cooled Interim Tier 4 John Deere
Turbo-charged Diesel.

PUMP:

All iron ANSI A80 centerline discharge centrifugal 750 GPM @ 115 psi,
1" particle clearance, axially adjustable, cartridge double mechanical
seal, features oil filled bearing housing.

DRIVE:

High speed flexible insert coupling.

AGITATION:

Primary 'Hydro-Jet' re-circulation system,
Secondary 'Multiflow' blending system.

MULCH GRINDER:

100-500 RPM 'Hydro-Jet' driven assembly.

DISCHARGE:

Full 360 degree articulation, pressure balanced, with ball bearing,
ductile iron rotary joint and full ported ball valve control.

NOZZLES:

Precision cast stainless steel quick disconnect type.
Set of three supplied; long range, medium range, and wide fan.

TRUCK:

Recommended minimum GVW is 64,000 lbs. (29,030 kg),
minimum CA is 144" (3.66 m) with 216" WB,

OPTIONAL EQUIPMENT:

Truck bed chassis mounting package.
Complete FMVSS dedicated vehicle Installation.
Cab over Deck Extension.
Hose reel and remote hose assemblies.
Spray bar options (cab or manual controls).
Air Gap Fill Assemblies.
Matched remote fill pump packages.

THE COMPLETE REINCO PRODUCT LINE:

HYDROGRASSERS:

8 Models, 200 to 3000 gallon working capacity.

POWER MULCHERS:

5 Models, 1-1/2 to 20 tons per hour mulch output.

Phone (800) 526-7687
Local (908) 755-0921
Fax (908) 755-6379
www.reinco.com

30GX3_SP20810G