

# HG-13GX3

## HYDROGRASSER

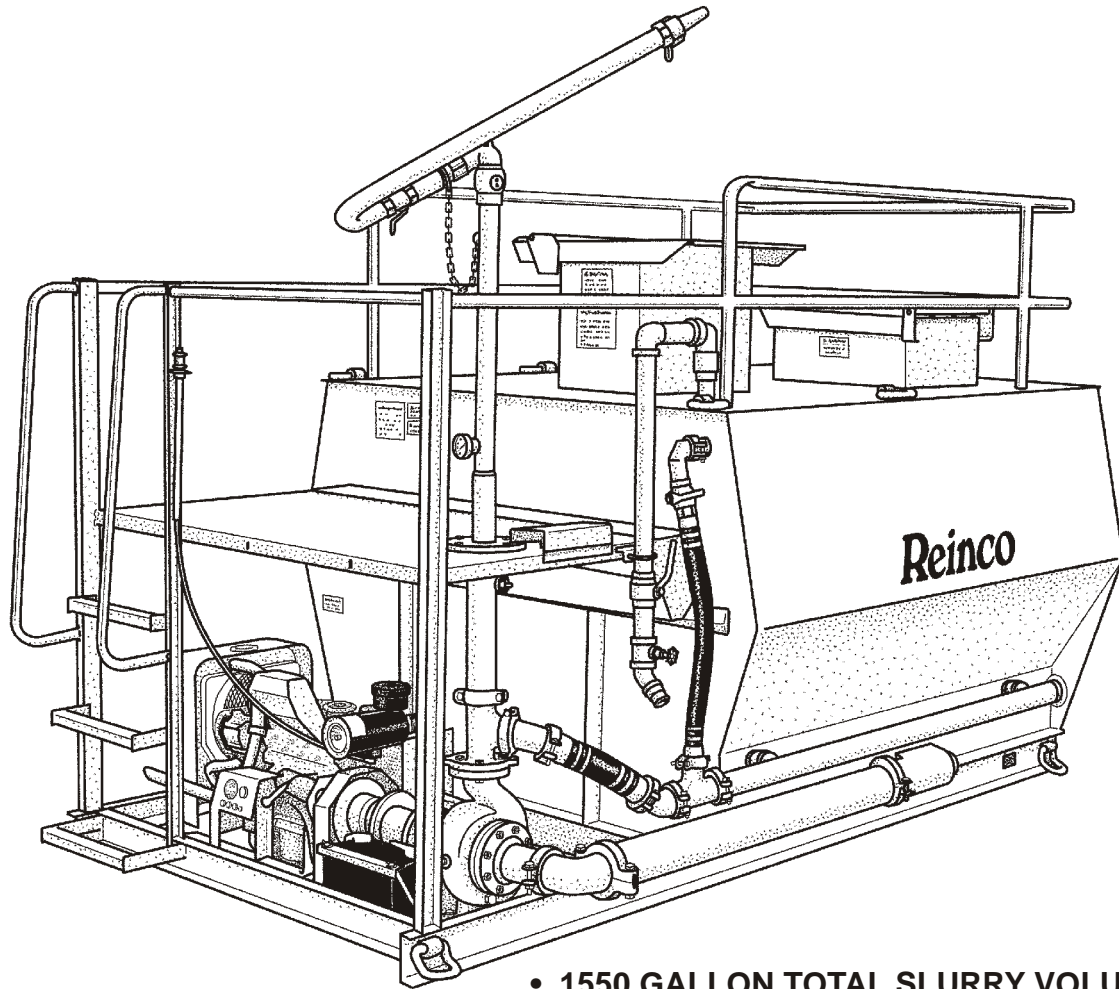

- 1550 GALLON TOTAL SLURRY VOLUME
- DUAL MIXING/BLENDER SYSTEM
- EXCLUSIVE FIBER MULCH GRINDER
- ANTI SIPHONING FILL STANDARD
- 33.5HP EC WATER COOLED DIESEL ENGINE
- SPRAY BAR AND HOSE REEL OPTIONS
- TRUCK BED OR CHASSIS MOUNT OPTIONS
- OPTIONAL REMOTE FILL PUMP PACKAGE

# Reinco

Power Mulching & Hydrograssing Machinery  
Reinco Inc. • PO Box 512 • Plainfield, NJ 07061-0512

Phone (800) 526-7687  
Local (908) 755-0921  
Fax (908) 755-6379  
[www.reinco.com](http://www.reinco.com)

# HYDROGRASSER • MODEL HG-13GX3

The Reinco HG-13GX3 Hydrograsser with 1550 total volume offers more capacity and required truck GVW is only 25,000 lbs. Simplicity of design keeps maintenance costs to a minimum. The proven 'Hydro-Jet' agitation system assures uniform mixing throughout the entire load. Two large hatches provide for fast, simultaneous materials charging. Materials are mixed as quickly as they are loaded, and ready to spray in minutes. Simplicity of design keeps maintenance costs to a minimum.

## FEATURES

The unique Reinco 'Hydro-Jet' primary agitation system produces a violently turbulent circulating action. Combining the exclusive 'Mulch Grinder' to shred mulch bales, with secondary vortexing 'Quad Blenders', charged materials are incorporated into a completely homogenous slurry mix. Engine power is reliably transmitted via flexible coupling directly to the axially adjustable all iron center line discharge centrifugal pump, combining mixing, recirculation and discharge via common manifold system. Dual charging hatches allow for simultaneous loading of batch materials. This proven system eliminates the high maintenance components of other systems. There are no belts, clutches, chains, sprockets and confusing controls. Anovice can operate the machinery as easily as the seasoned professional.

Tank formed and fabricated of 3/16" carbon steel sheet with 1/4" structurally reinforced end plates. Frame and modular components are formed and fabricated from carbon steel and structurals, and welded throughout. Piping consists of electrically welded steel components featuring predominantly grooved mechanical pipe ends; drain and cleanout connections supplied with cam style couplings for easy servicing. Ladder and safety railings are fabricated integrally to the completed machine.

Heavy duty four cylinder engine is standard with 12V ignition, battery, flywheel alternator and starter, two stage dry evacuator type aircleaner with precleaner, governor and chaff screen. Fuel tank capacity is 12 gallons. Keyed ignition, hourmeter, ammeter, are cluster mounted on the engine cowling. Quick setting vernier type, weatherproof throttle mounted for operator access. Foot operated signal horn, provides on site communication for vehicle operator and crew.

Tank interior coated with high solids aluminized epoxy. Machine primed, sanded and finished with durable lead free Reinco yellow modified acrylic enamel. Platform and tank top are provided with anti-skid coating. Operational and safety decals complete the installation.

All Reinco machinery is factory tested and shipped complete and ready to work.

***Call about your specific application requirements!***

## THE COMPLETE REINCO PRODUCT LINE:

### **POWER MULCHERS:**

5 Models, 1-1/2 to 20 tons per hour mulch output.

### **HYDROGRASSERS:**

8 Models, 200 to 3000 gallon working capacity.

## SPECIFICATIONS

### **CAPACITY**

1300 Gallons (4,920 l) working volume (water)  
1550 Gallons (5,870 l) total volume (combined slurry)  
Granular solids: 3000 lbs. (1361 kg)  
Processed Fiber Mulch: 650 lbs. (295 kg)

### **EFFECTIVE RANGE**

130 foot (39.6 m) from platform  
400 foot (120 m) with extension hose

### **SIZE:**

Length 12'-3" (3.8 m) w/reel option 14'-6" (4.5m)  
Width 7'-6" (2.3 m)  
Height 8'-0" (2.44 m).  
Volume 714 cu. feet (21 cu. m).

### **WEIGHT**

Standard unit 3800 pounds (1724 kg).  
Fully charged 17,200 lbs (7,802 kg)

### **ENGINE**

Water cooled EC diesel engine rated 33.5 HP @ 3000 RPM

### **PUMP**

All iron end suction centrifugal 400GPM @ 70 psi,  
1-1/8" particle clearance, Pressurized Double Mechanical Seal

### **DRIVE**

High speed flexible insert coupling

### **AGITATION**

Primary 'Hydro-Jet' recirculation system  
Secondary 'Quad-Blender' vortexing system

### **MULCH GRINDER:**

100-500 RPM 'Hydro-Jet' driven assembly

### **SPRAY BOOM**

Full 360 degree articulation, pressure balanced,  
ball bearing, ductile iron rotary joint with full ported ball valve control.

### **NOZZLES:**

Precision cast stainless steel quick disconnect type.  
Set of three supplied; long range, medium range and fan.

### **TRUCK**

Recommended 12 ft platform body  
minimum GVW is 25,000 lbs  
minimum CA is 102"

### **OPTIONAL EQUIPMENT**

Air Gap Fill Assembly  
Hose reel and remote hose assemblies  
Remote fill pump with accessories  
Spray bars (cab or manual controls)  
Truck mounting packages

# Reinco

Power Mulching & Hydrograssing Machinery  
Reinco Inc. • PO Box 512 • Plainfield, NJ 07061-0512

Phone (800) 526-7687  
Local (908) 755-0921  
Fax (908) 755-6379  
[www.reinco.com](http://www.reinco.com)